



### Operating Conditions

**50HZ**

1. Ambient temperature: 0°C~+40°C.
2. Liquid temperature: 0°C~+40°C.
3. 24Hr continuously running is allowed.

### Applications

1. Wastewater treatment of all industries.
2. River, ponds, lakes dredging.
3. Artificial flow of amusement facilities.
4. Mix and agitate impurities in the water.

### Motor Spec.

1. Voltage: Only Three phase
2. Frequency: 50HZ
3. Enclosed class: IP68
4. Insulation: F
5. Pole: 4P
6. Built in motor overload protector

### Construction

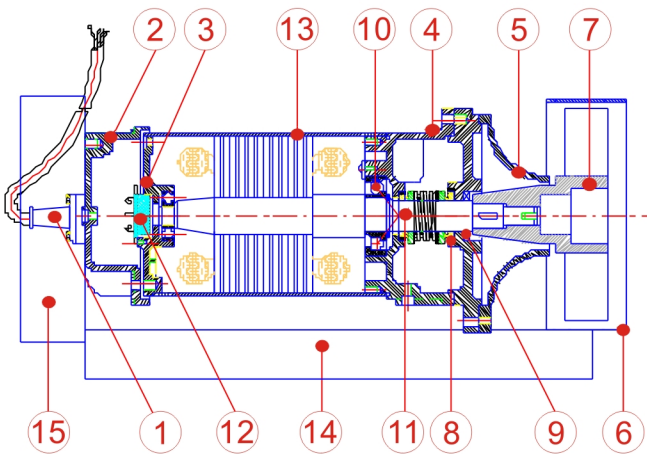

NO.	NAME	MATERIAL
1	Cable	STOW
2	Motor upper cover	FC200
3	Bearing housing	FC200
4	Bracket	FC200
5	Inlet housing	FC200
6	Jet Ring	SUS304
7	Mixer impeller	FCD450
8	Mechanical seal	SIC/SIC
9	Oil seal	VITON
10	Bearing	(NTN brand)
11	Shaft	SUS304
12	Overload protector	(T.I.brand)
13	Motor housing	SUS304
14	Support base	SUS304
15	Seat for guide rail device	SUS304

### Specification & Dimensions

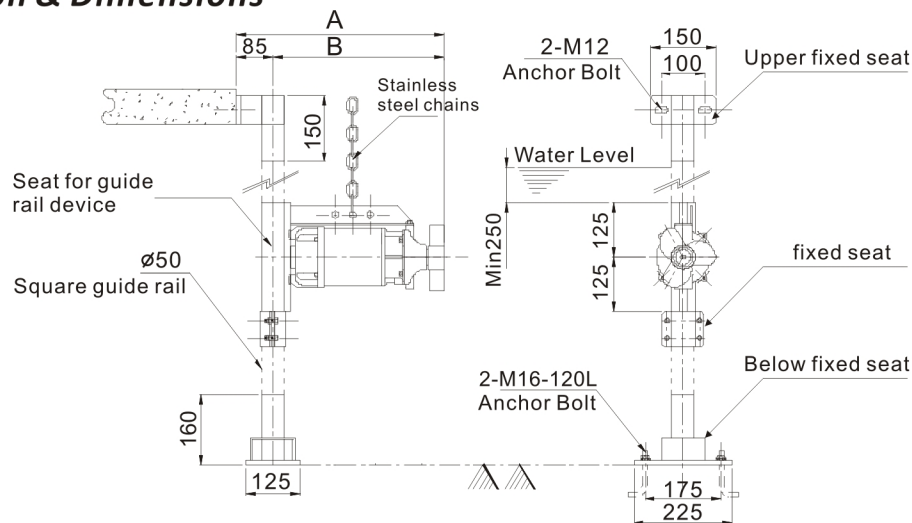

Model	Output		Pole	Capacity	Flow Speed	Dimensions(mm)	
	KW	HP				A	B
EFM-05T	0.40	1/2	4	108	1.78	480	395
EFM-10T	0.75	1	4	192	2.02	510	425
EFM-20T	1.50	2	4	270	2.50	632	567
EFM-30T	2.20	3	4	408	3.50	652	587