

Expertise comes in all sizes

End Suction Pumps - as per ISO 2858

General Information



Wilo – MISO Pumps

Special Features

- All pumps are as per ISO 2858
- End suction top discharge
- Grease lubricated antifriction bearings.
- Back pull out design eases for maintenance of the pump without disturbing the motor and piping arrangement.
- Sealing gland packed or mechanical seal.
- Pressure and temperature gauge connections on casing.
- Supplied with flanges as per ANSI 16.1/16.5 standards.
- Reduced life-cycle costs through optimized efficiency level





Application

- Chemical and Process
- Water supply
- HVAC
- Irrigation and sprinkler system
- Municipal water supply
- General Industry
- Fire Fighting
- Jockey pump

Standard Materials

- Casing: Cast Iron, NI-CI
- Impeller: Cast Iron, Bronze (Copper Alloy), Stainless Steel
- Shaft: Stainless Steel, (SS316, SS410)
- Shaft Sleeve: Stainless Steel (SS410, SS316)
- Casing wear ring: Cast Iron, Bronze, Stainless Steel
- Sealing: Mechanical seal/gland pack

Accessories

- Companion flange
- Foundation bolts
- Shims

Description/Design

End suction pump as per ISO 2858

Type key (Pump Model)

Example	MISO 32-125
MISO	Standard Pump with Axial Suction
32	Discharge
125	Impeller nominal diameter

Technical Data

- End suction pumps : 37 models
- Series: MISO
- Nominal sizes: DN32 mm up to DN200 mm
- Flow range: up to 750 m³/hr.
- Head range: up to 170 m.
- Operating pressure: 16 bar
- Operating Temp.: 0°C to 105 °C for Gland packed
-20°C to 120 °C for Mech. seal
- Mounting: Horizontal, vertical (optional)
- Lubrication: Grease, oil
- Direction of rotation: Clockwise

Scope of delivery

- Pump
- As a complete pump set including electrical motor base plate, coupling and coupling guard.
- Either without motor **or**
- As bare shaft pump without base plate

Sectional Drawing

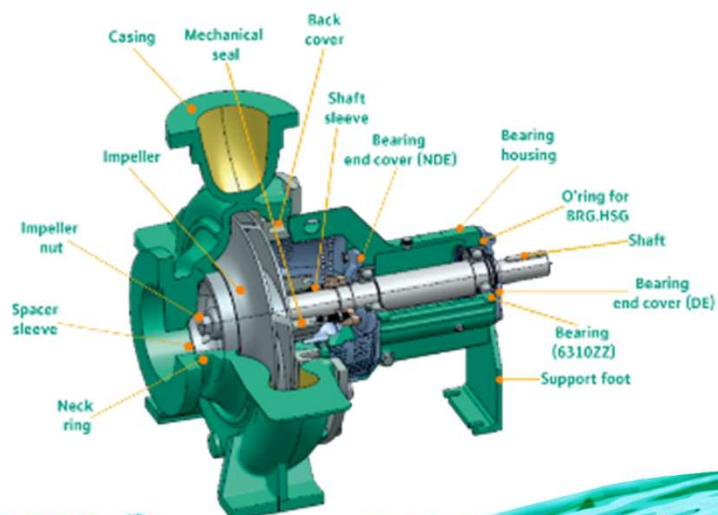

MISO - 25 - 125 (2 - Pole)

Performance curve

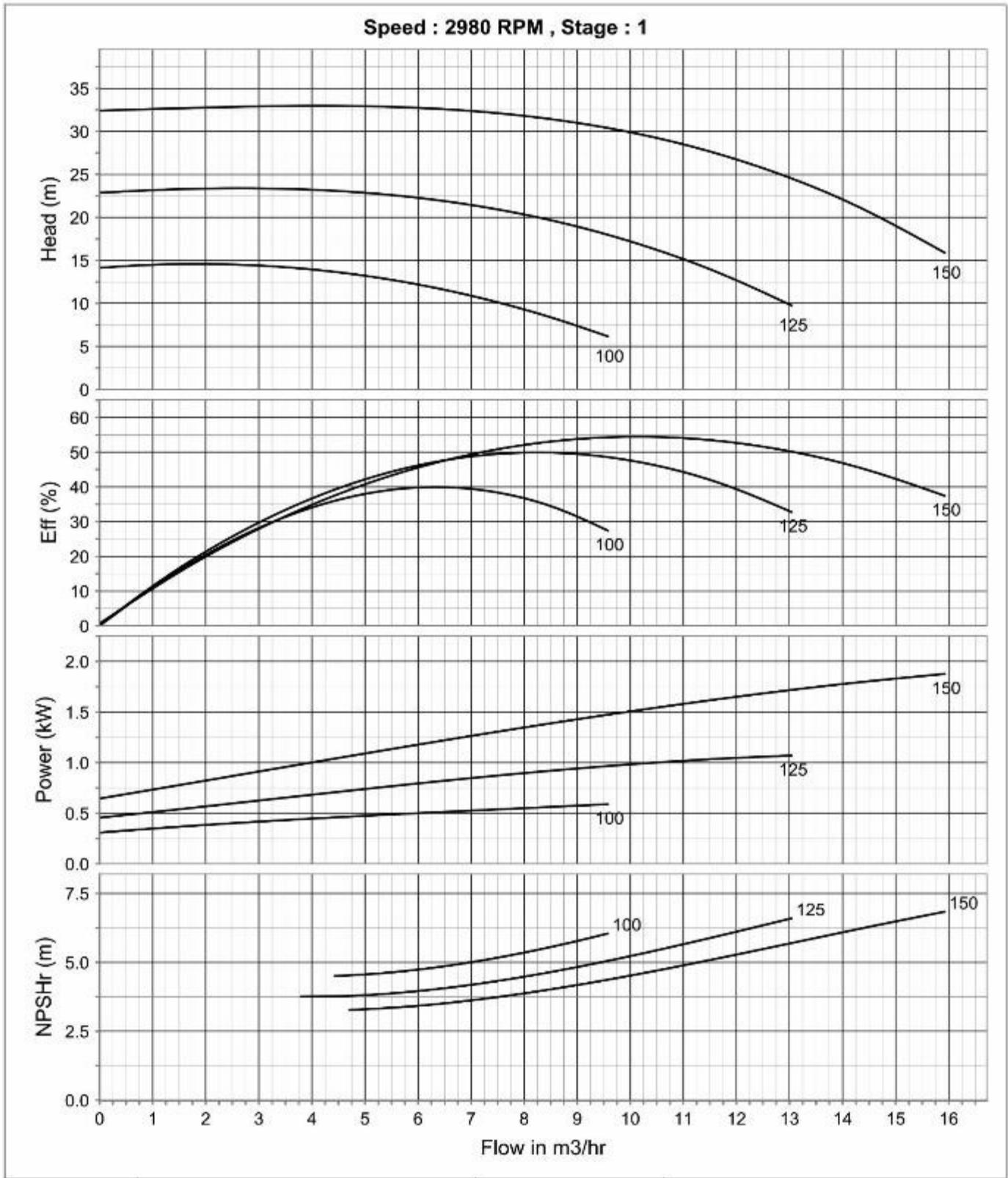

Performance Curve 2 Pole

MISO - 25 - 160 (2 - Pole)

Performance curve

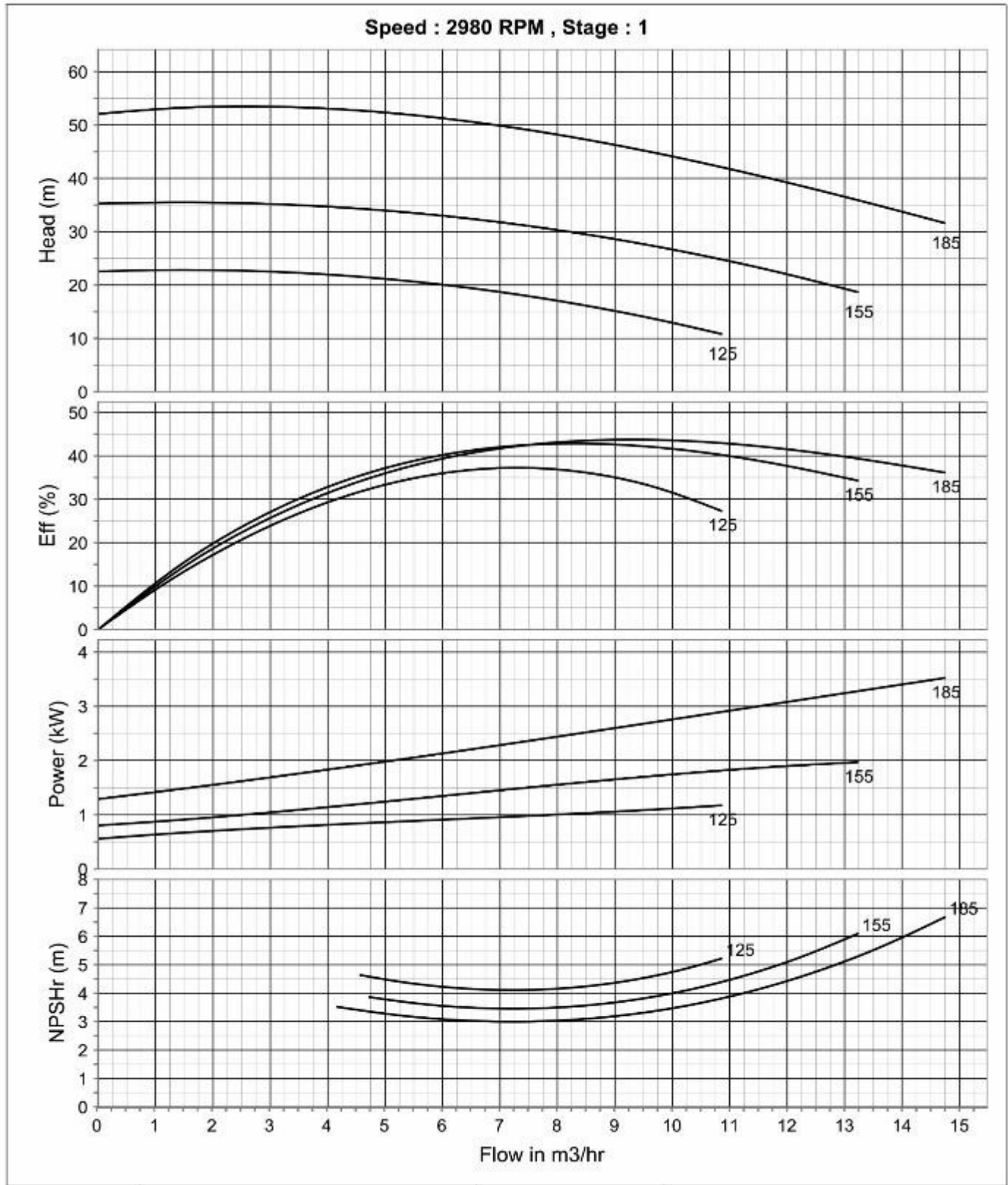

Performance Curve 2 Pole

MISO - 32 - 125 (2 - Pole)

Performance curve

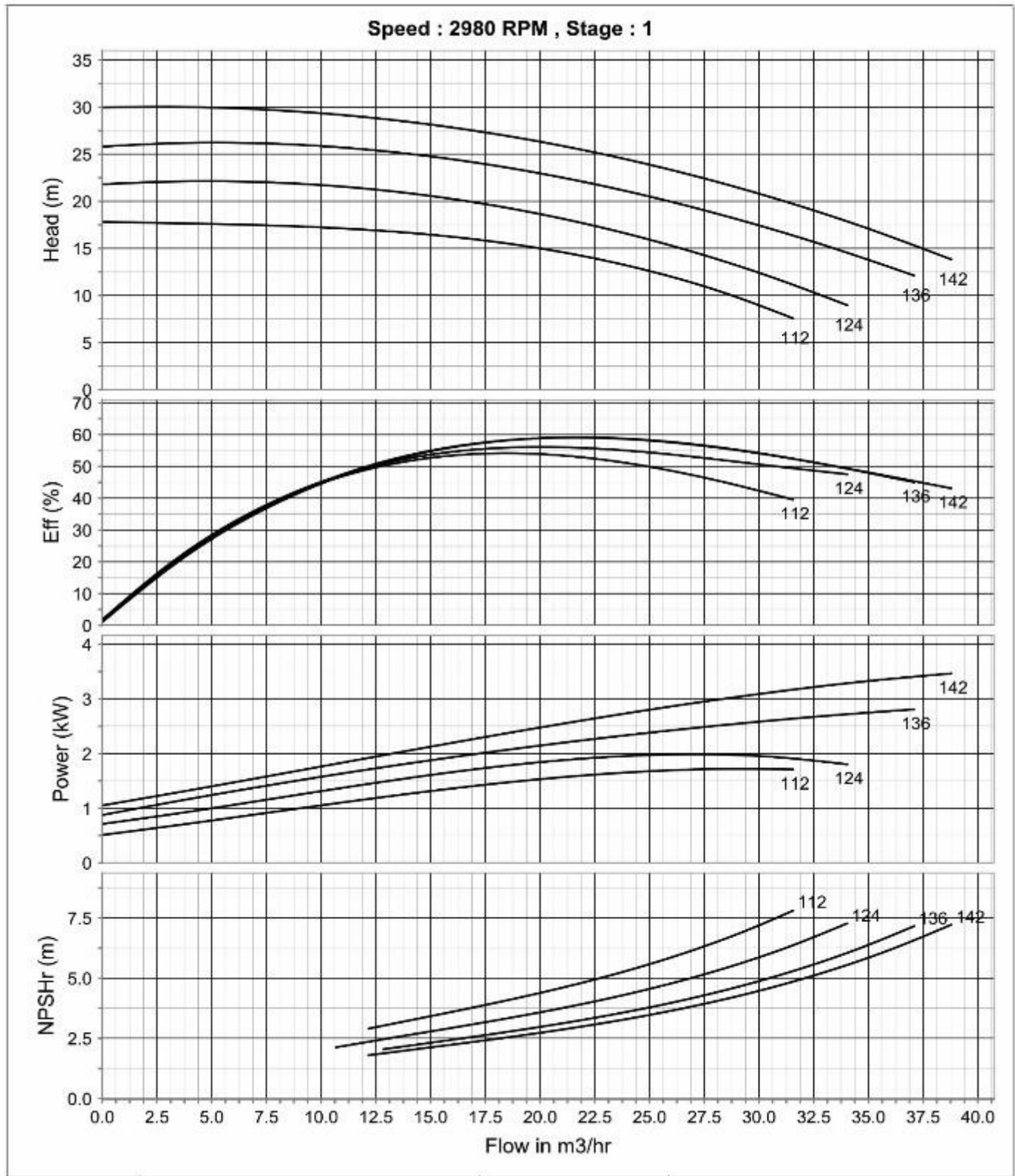

Performance Curve 2 Pole

MISO - 32 - 160 (2 - Pole)

Performance curve

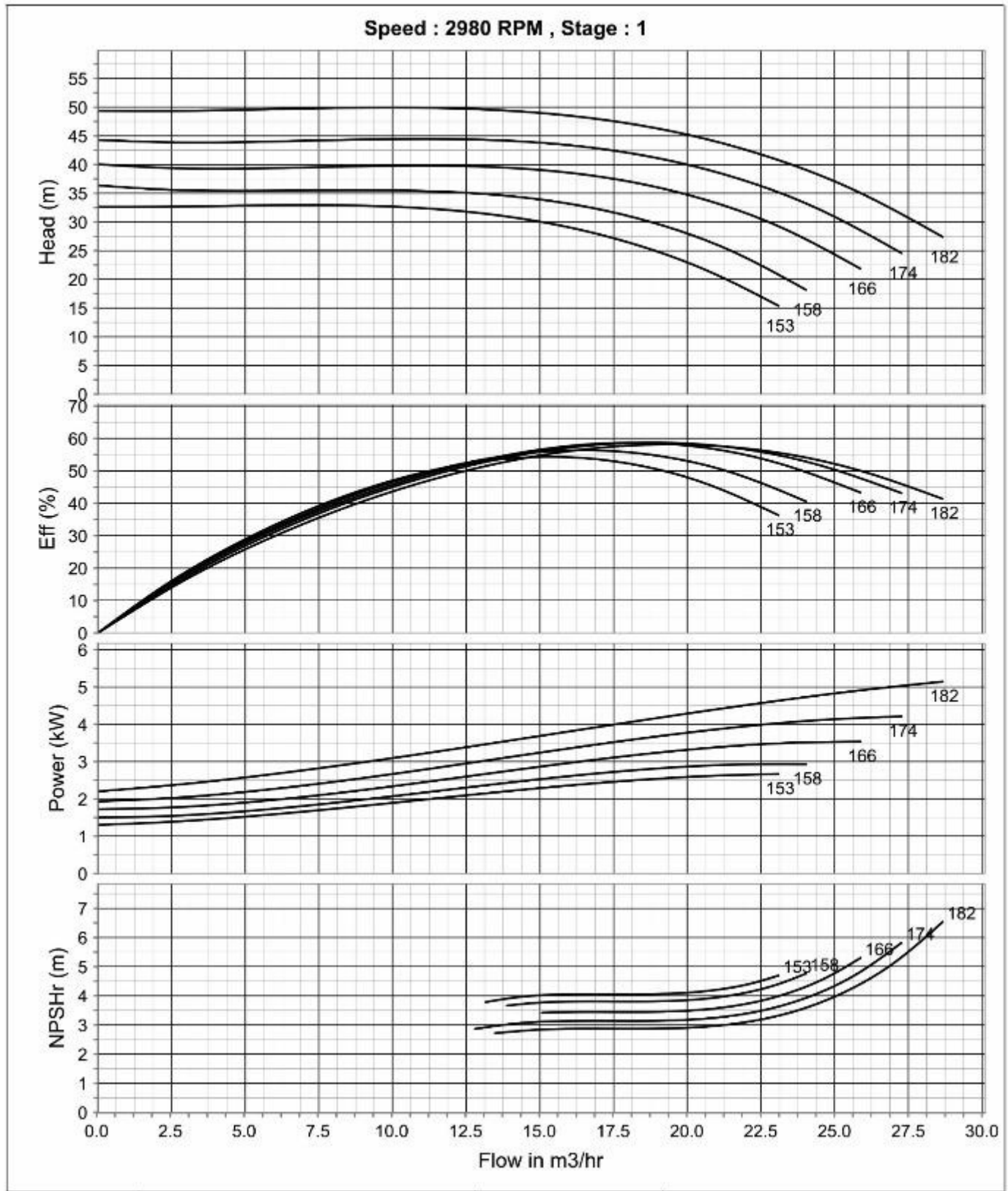

Performance Curve 2 Pole

MISO - 32 - 200 (2 - Pole)

Performance curve

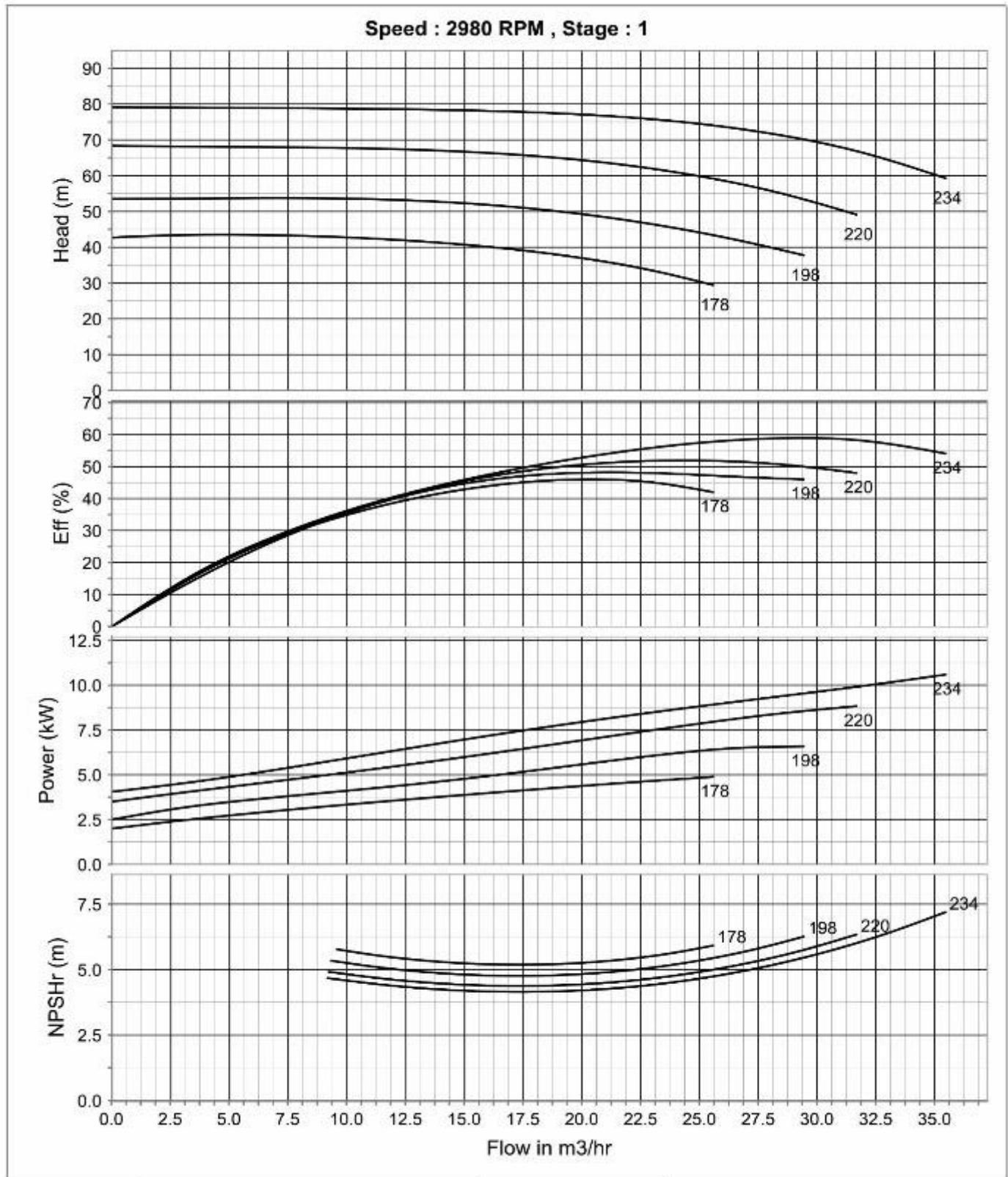

Performance Curve 2 Pole

MISO - 32 - 250 (2 - Pole)

Performance curve

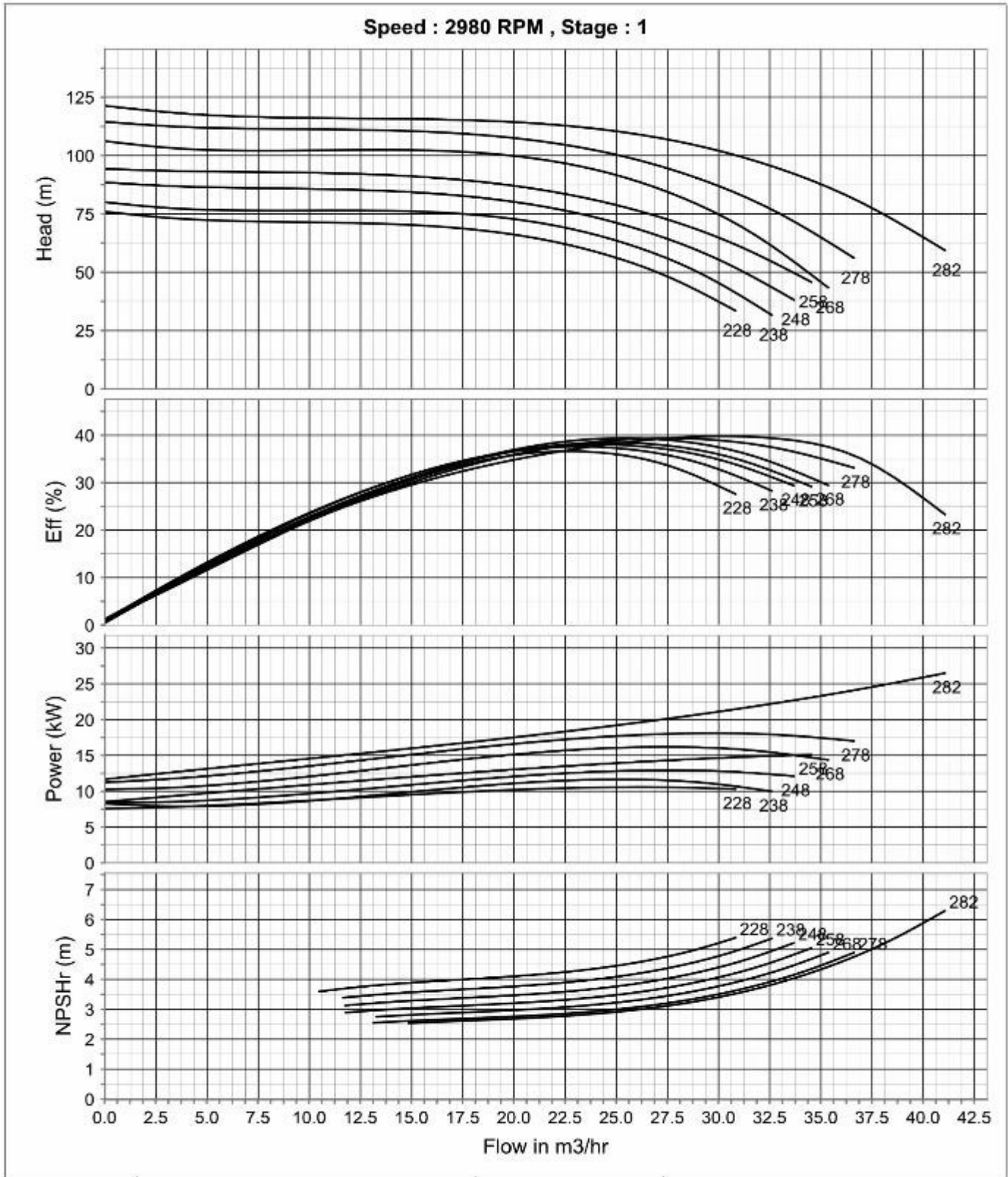

Performance Curve 2 Pole

MISO - 40 - 200 (2 - Pole)

Performance curve

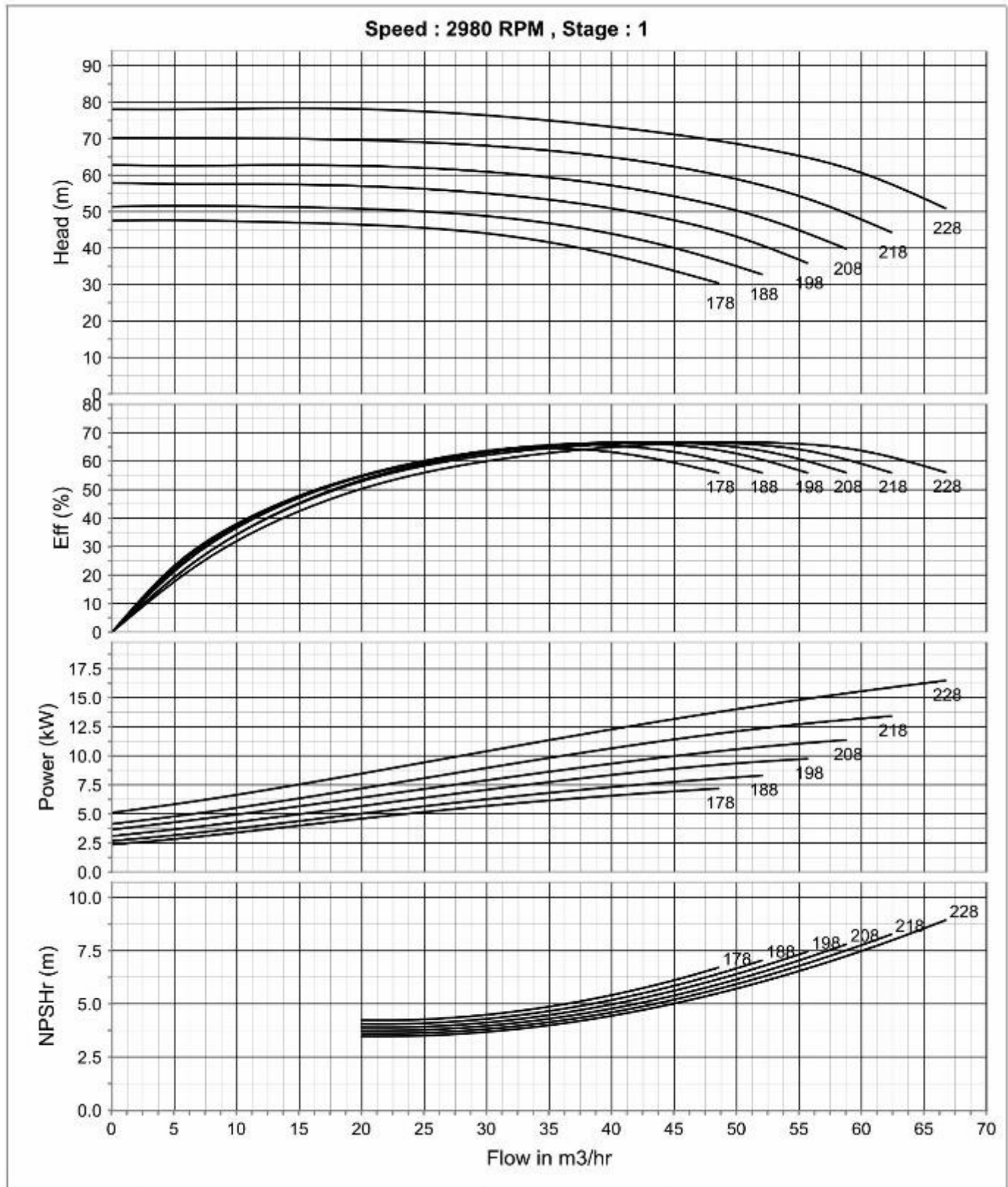

Performance Curve 2 Pole

MISO - 40 - 250 (2 - Pole)

Performance curve

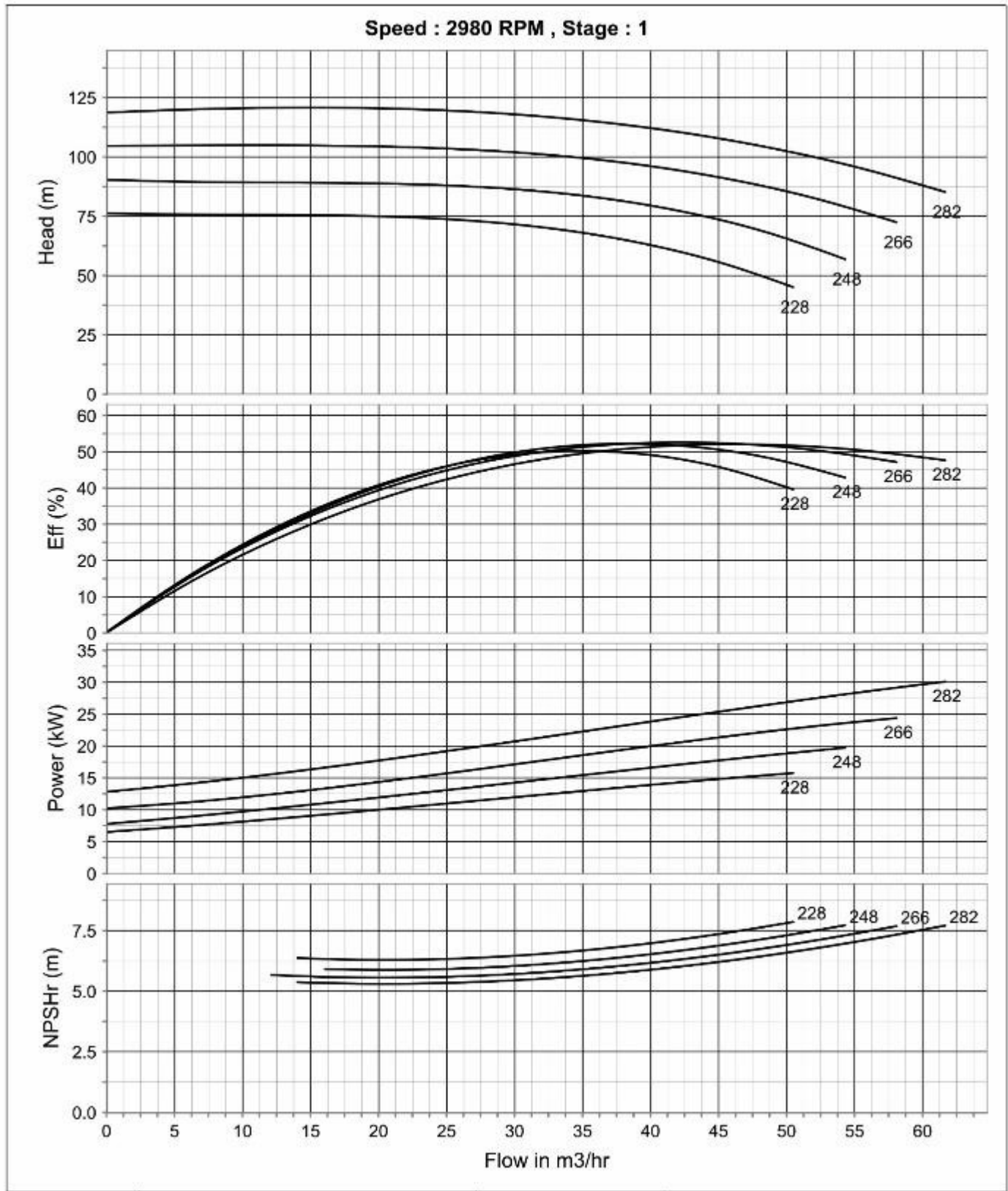

Performance Curve 2 Pole

MISO - 40 - 315 (2 - Pole)

Performance curve

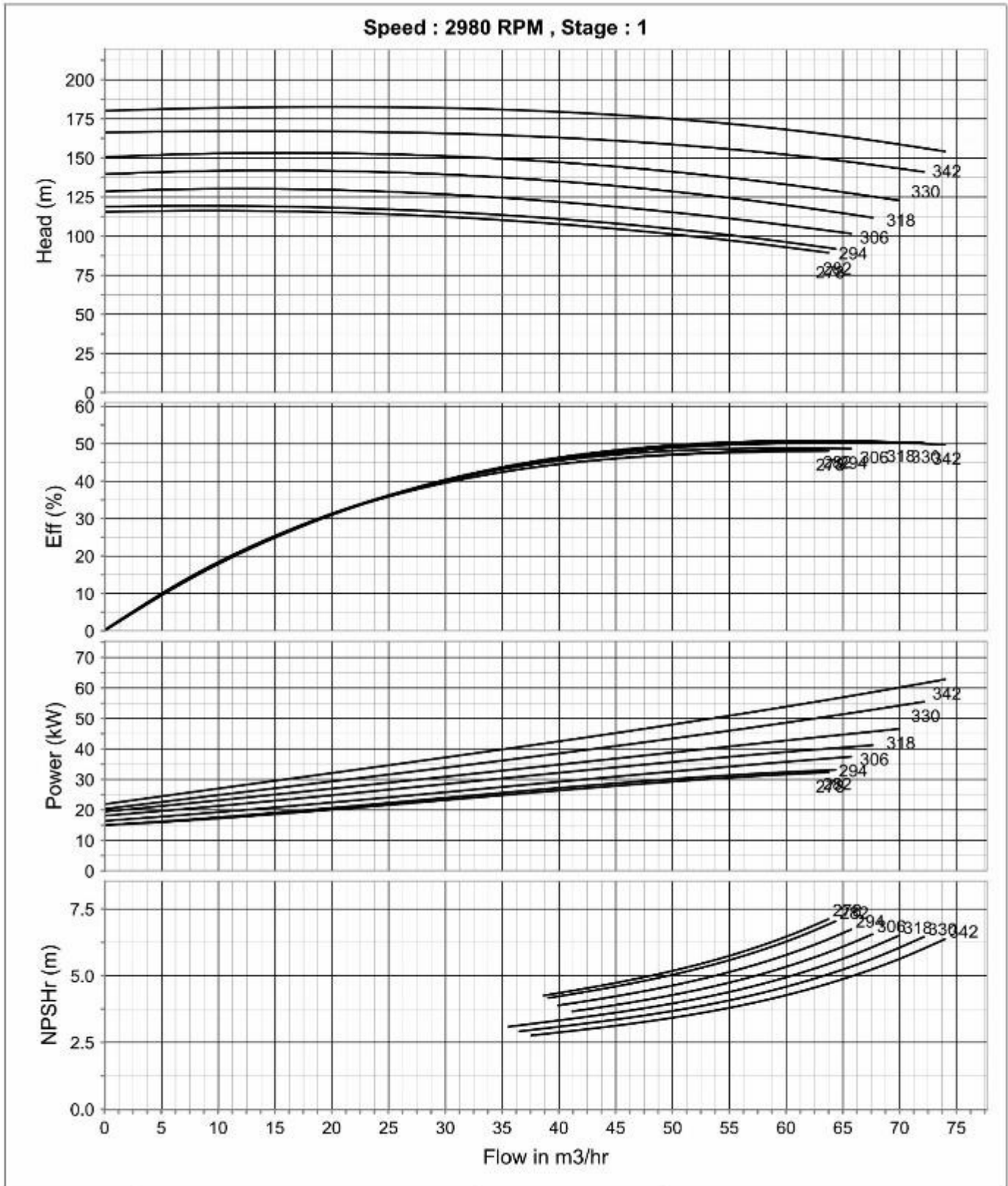

Performance Curve 2 Pole

MISO - 50 - 125 (2 - Pole)

Performance curve

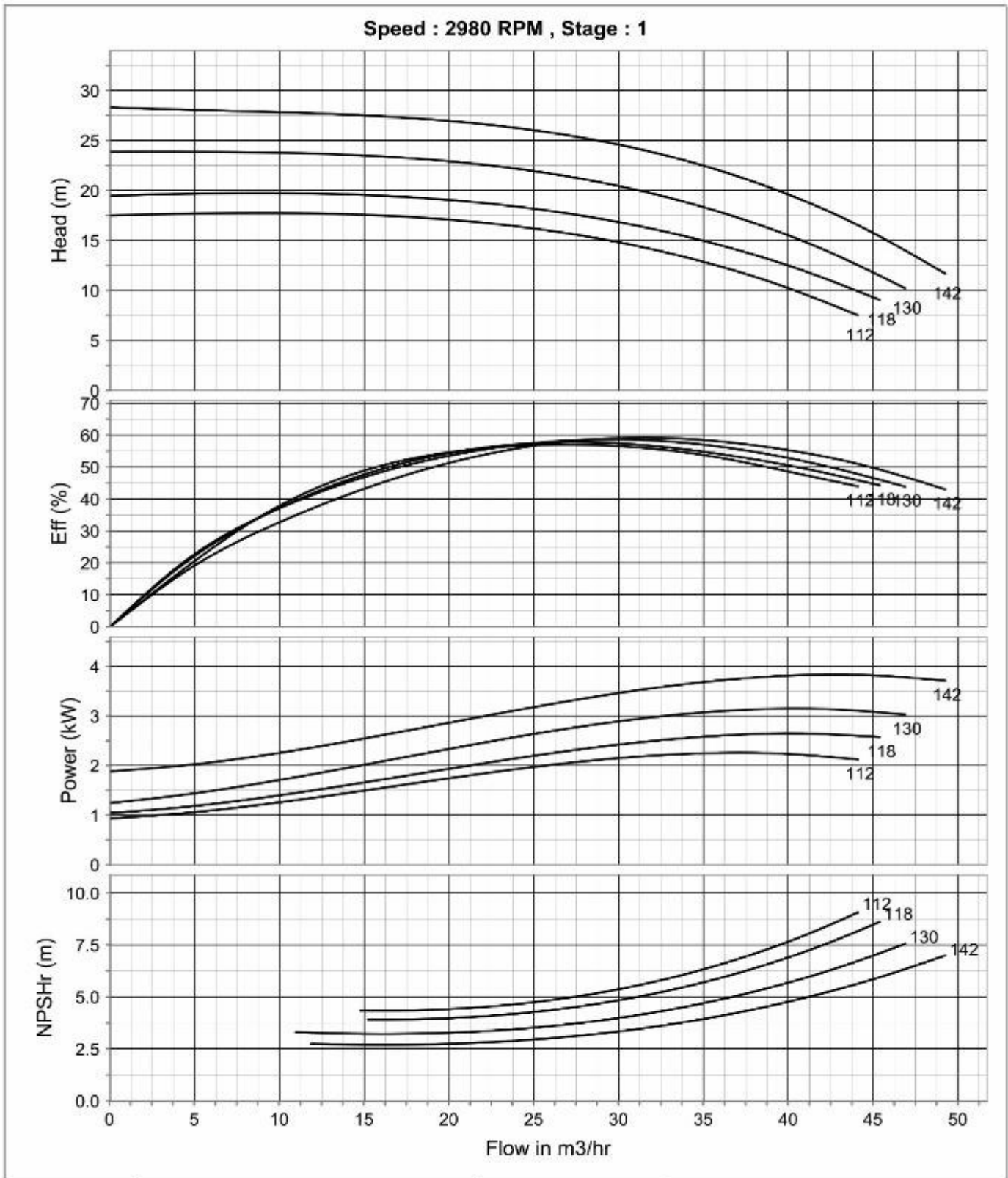

Performance Curve 2 Pole

MISO - 50 - 160 (2 - Pole)

Performance curve

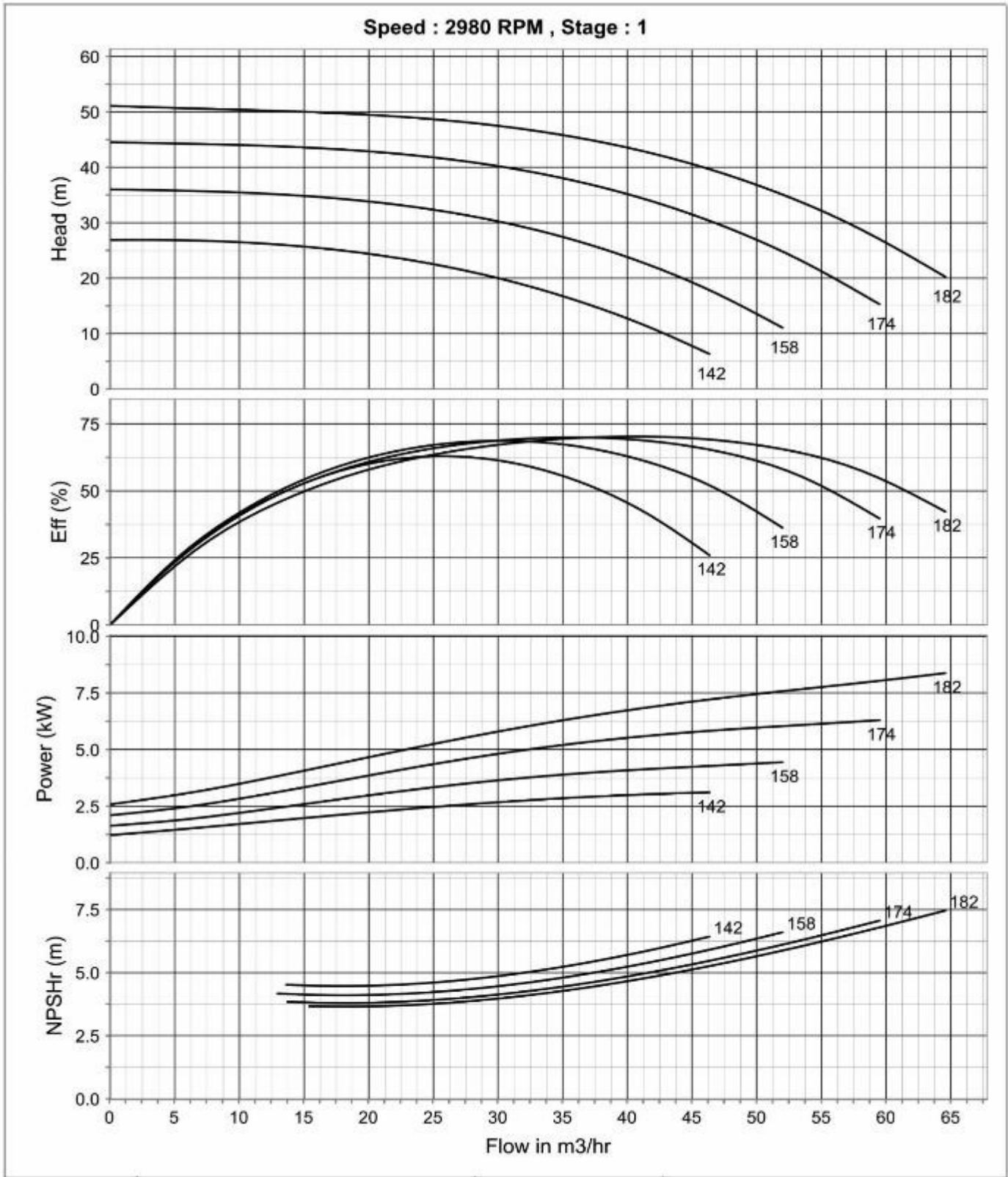

Performance Curve 2 Pole

MISO - 50 - 200 (2 - Pole)

Performance curve

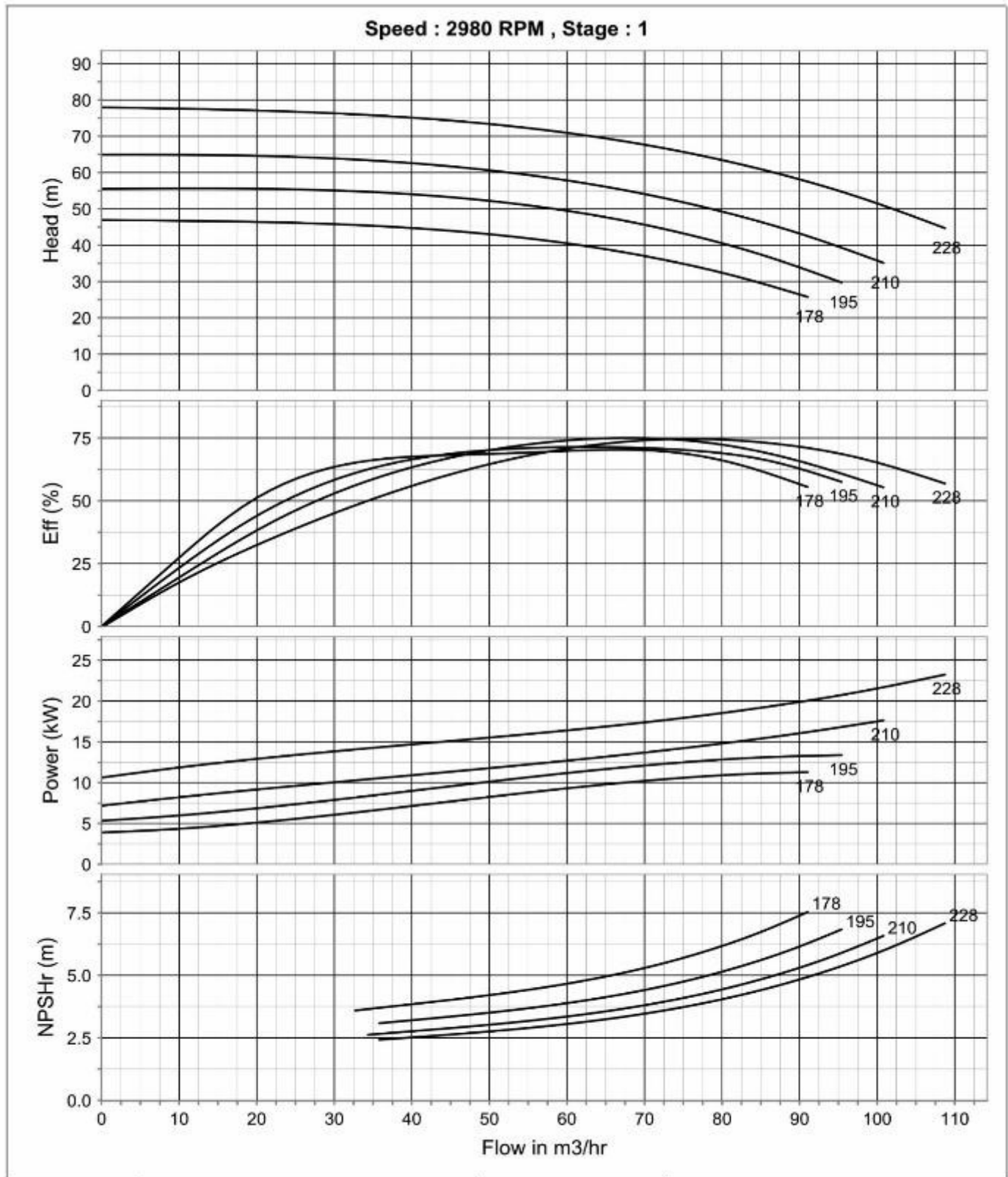

Performance Curve 2 Pole

MISO - 50 - 250 (2 - Pole)

Performance curve

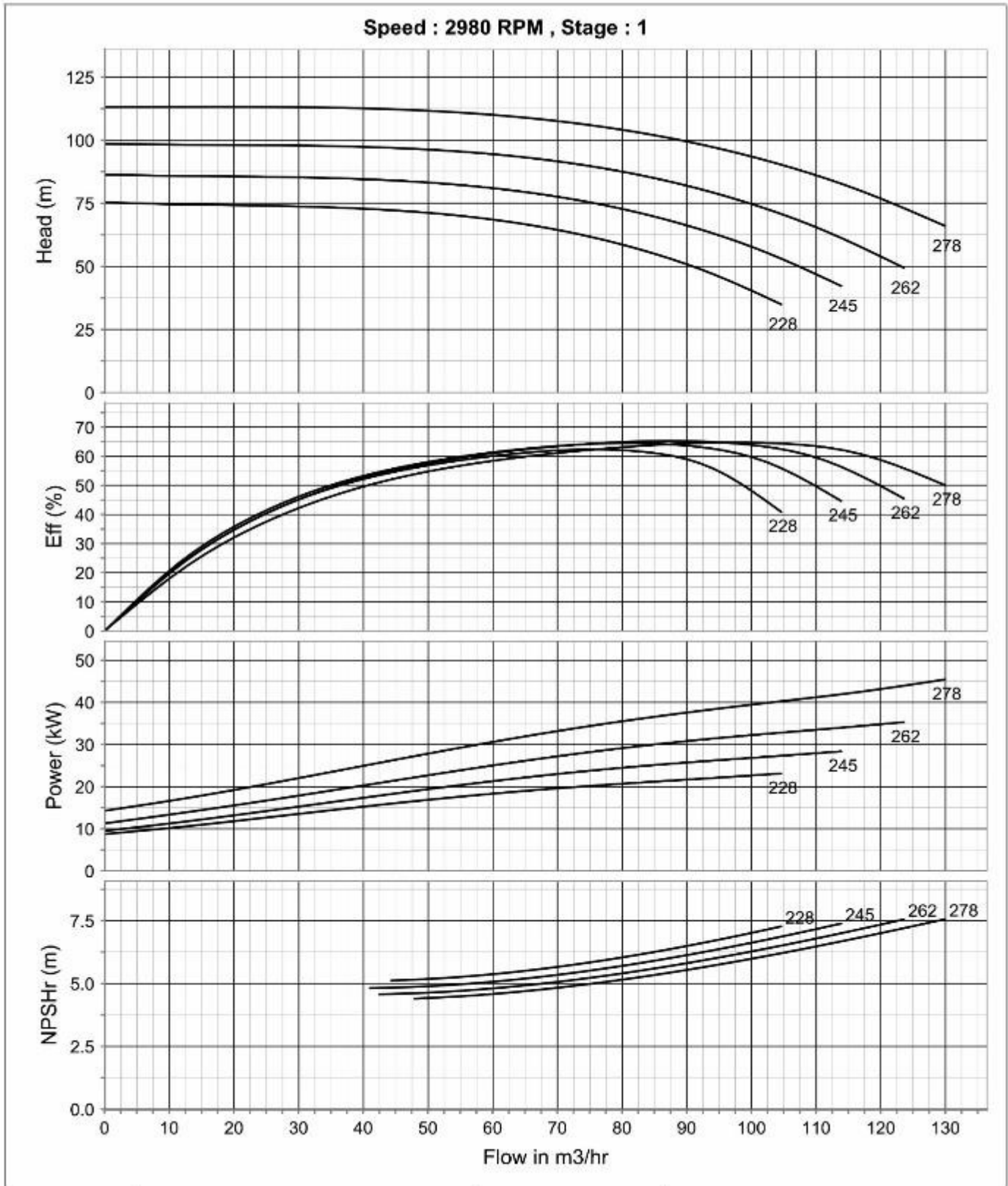

Performance Curve 2 Pole

MISO - 50 - 315 (2 - Pole)

Performance curve

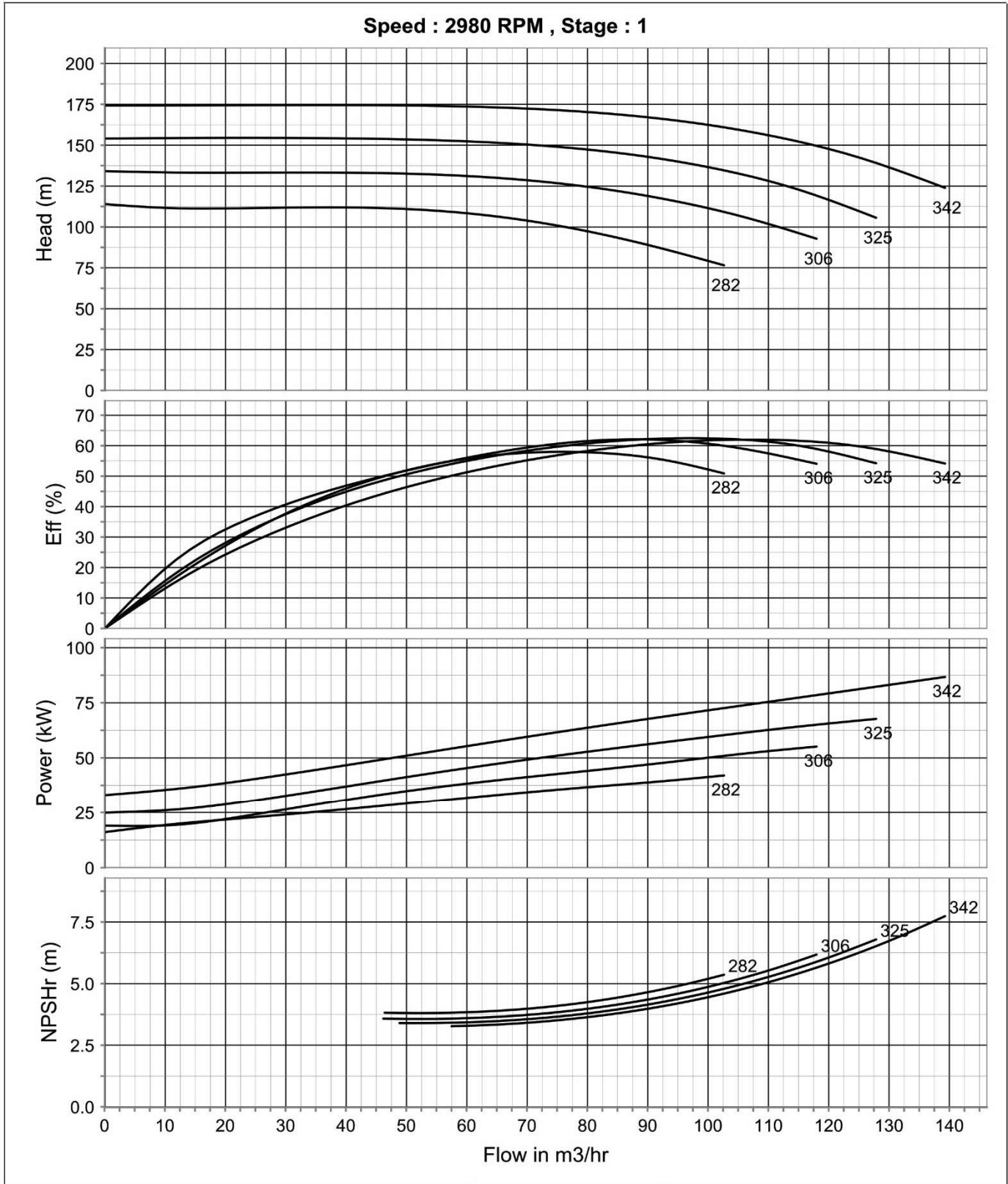

Performance Curve 2 Pole

MISO - 65 - 125 (2 - Pole)

Performance curve

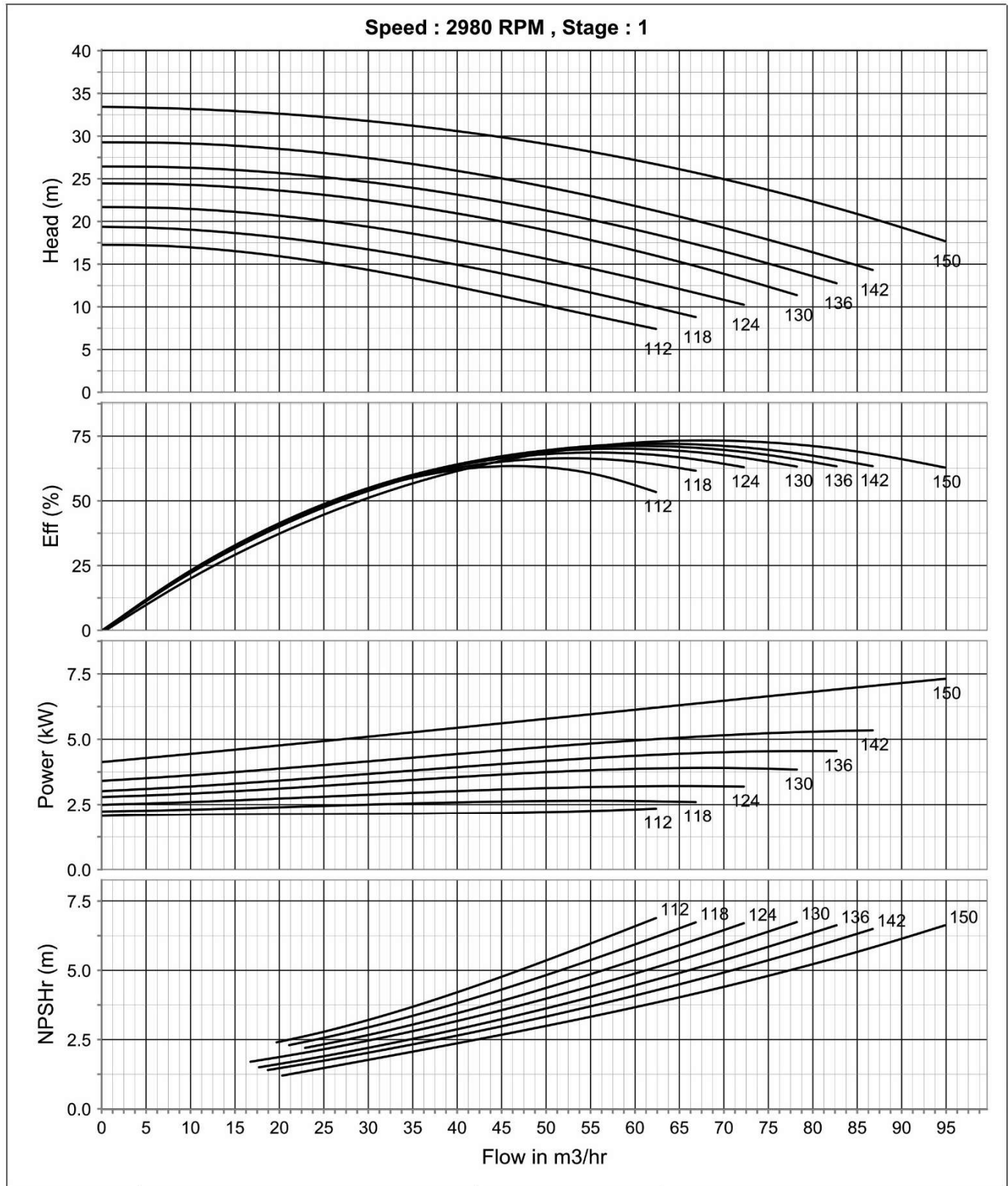

Performance Curve 2 Pole

MISO - 65 - 160 (2 - Pole)

Performance curve

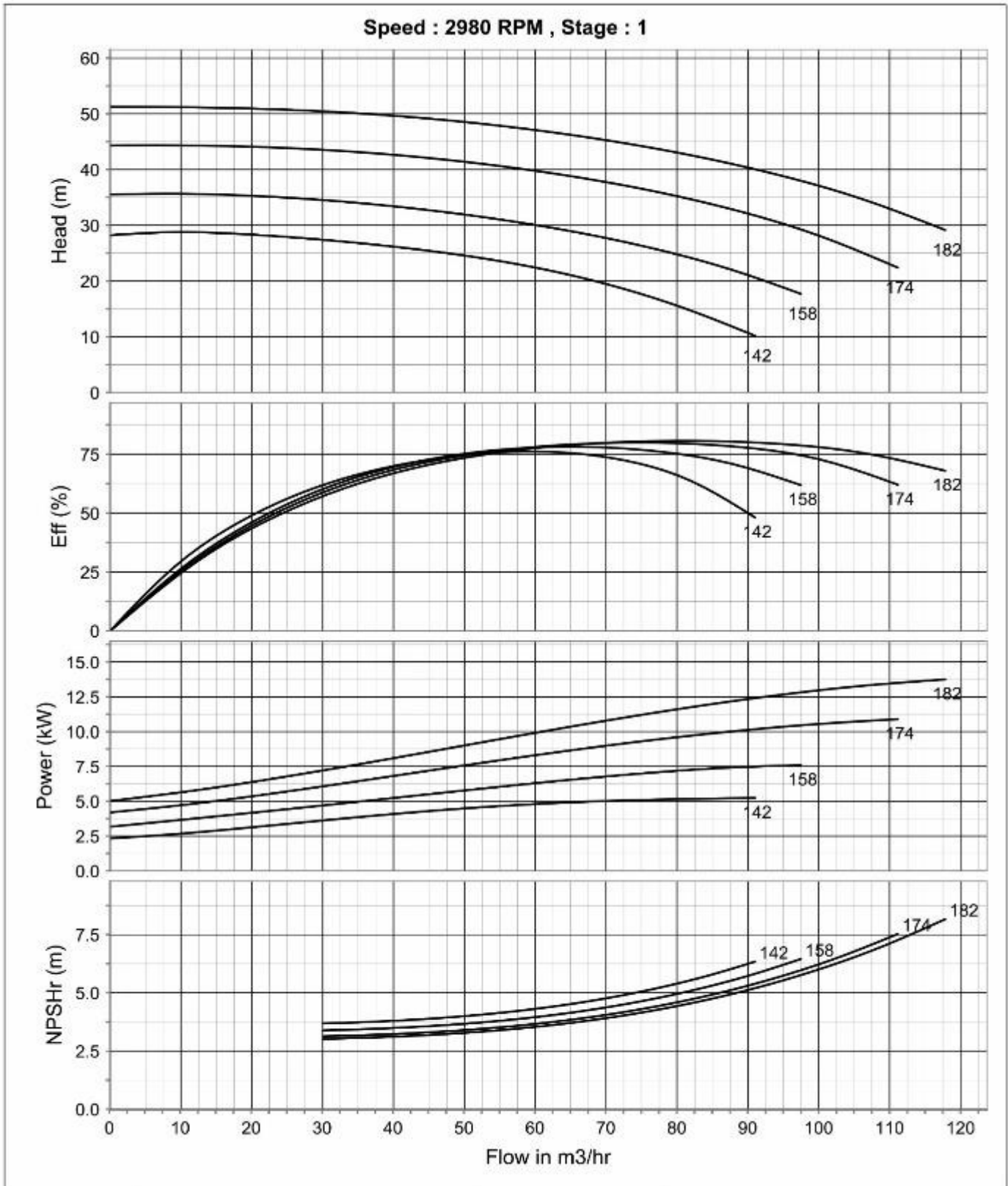

Performance Curve 2 Pole

MISO - 65 - 200 (2 - Pole)

Performance curve

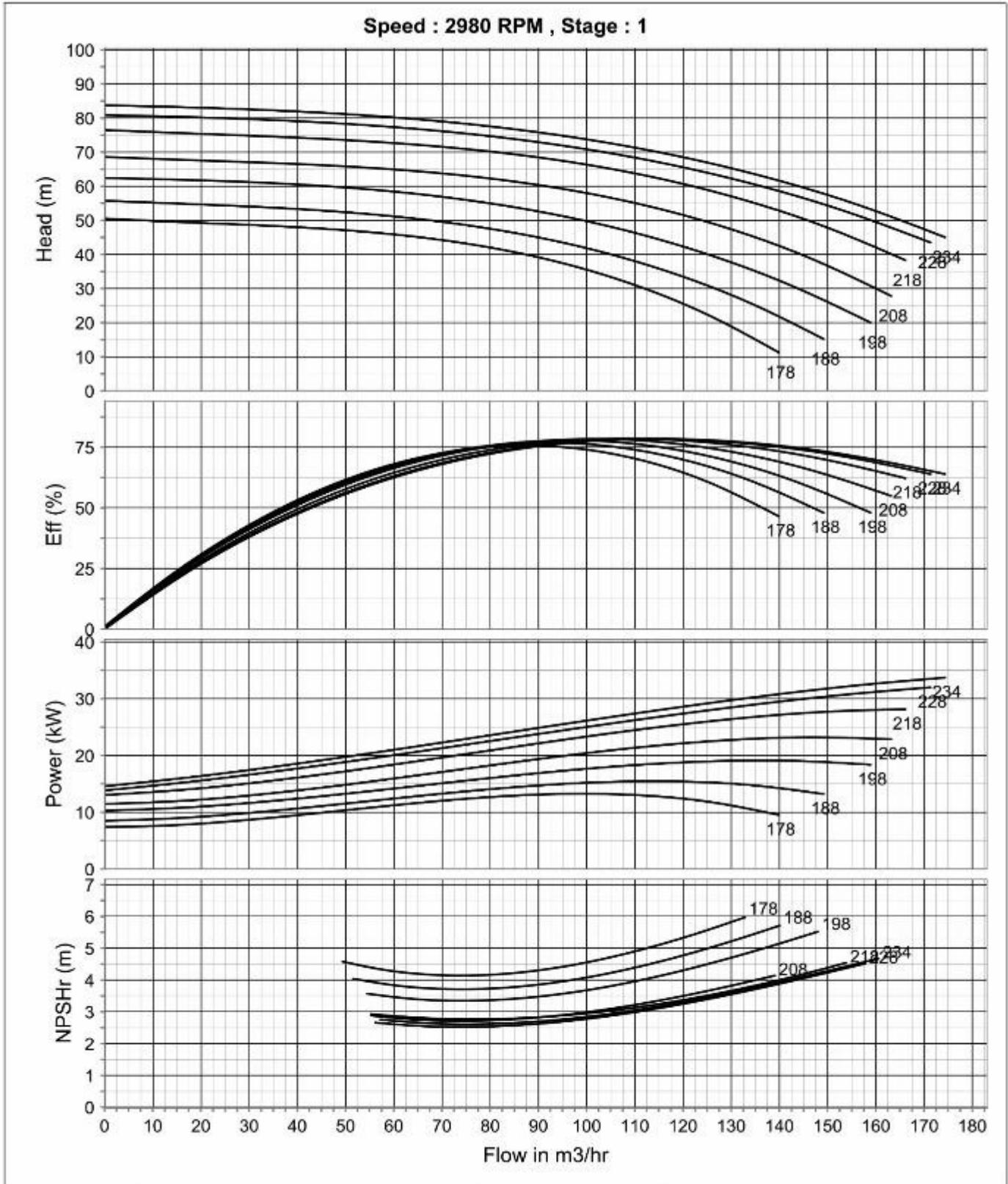

Performance Curve 2 Pole

MISO - 65 - 250 (2 - Pole)

Performance curve

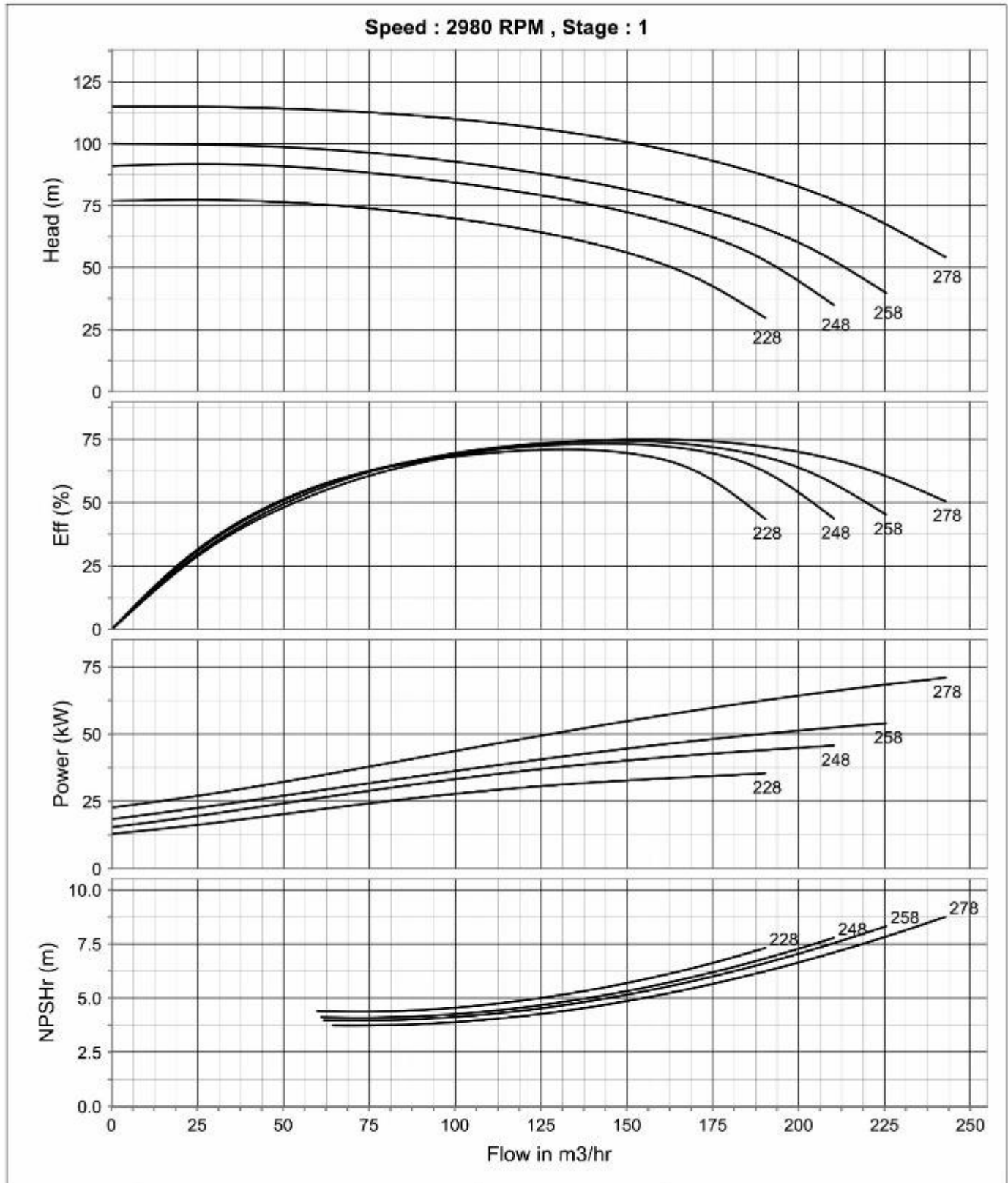

Performance Curve 2 Pole

MISO - 65 - 315H (2 - Pole)

Performance curve

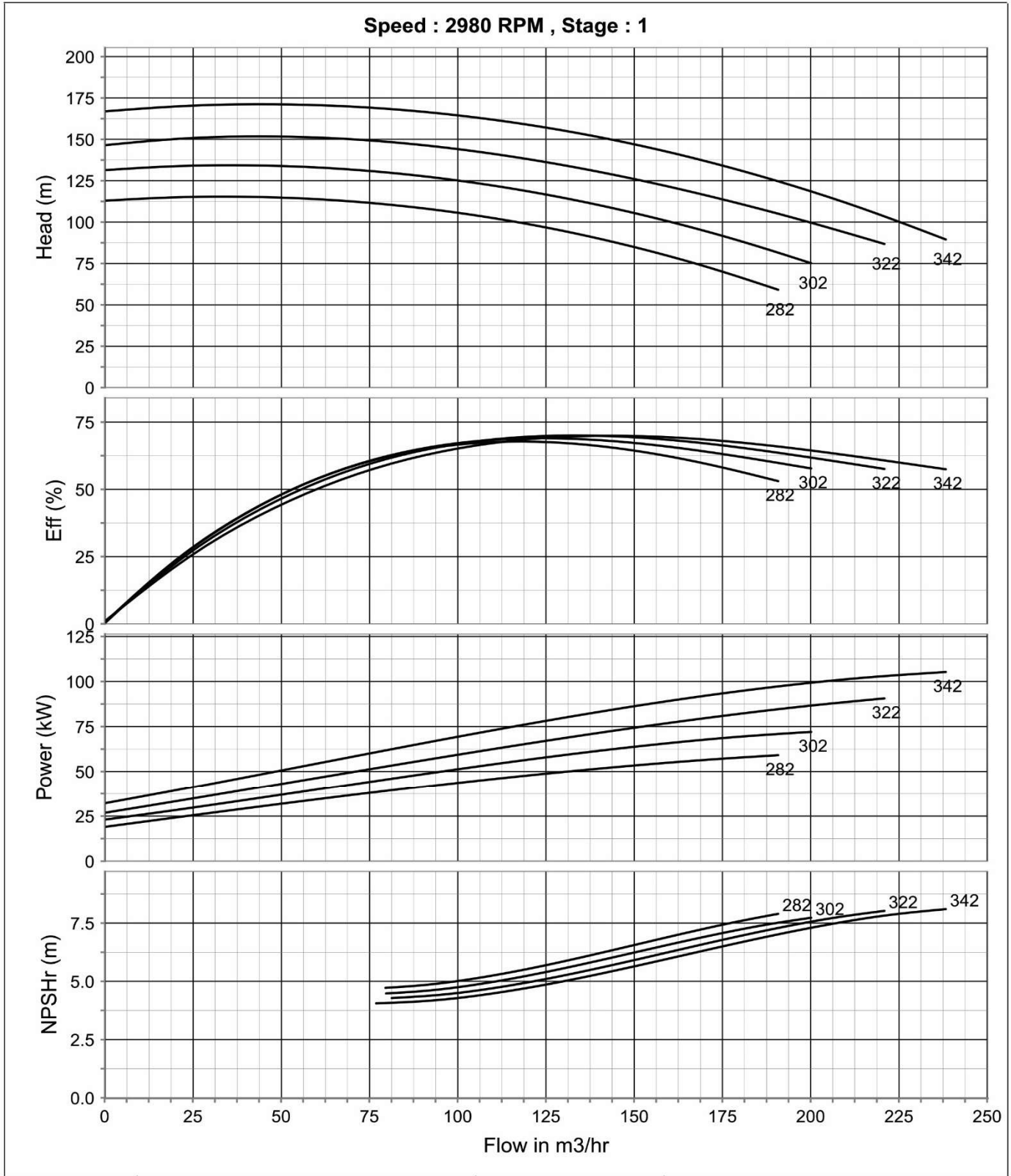

Performance Curve 2 Pole

MISO - 80 - 250 (2 - Pole)

Performance curve

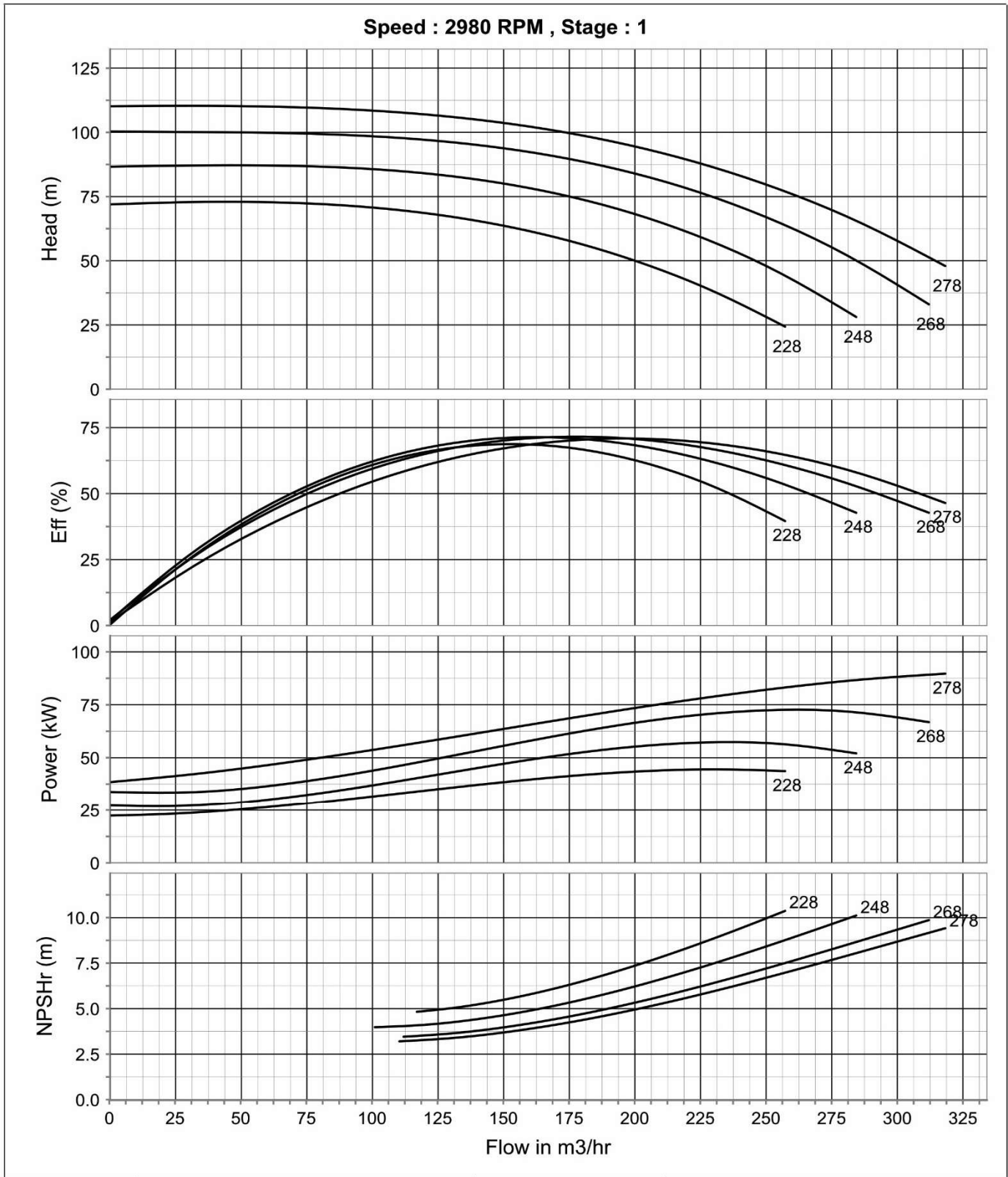

Performance Curve 2 Pole

MISO - 100 - 200 (2 - Pole)

Performance curve

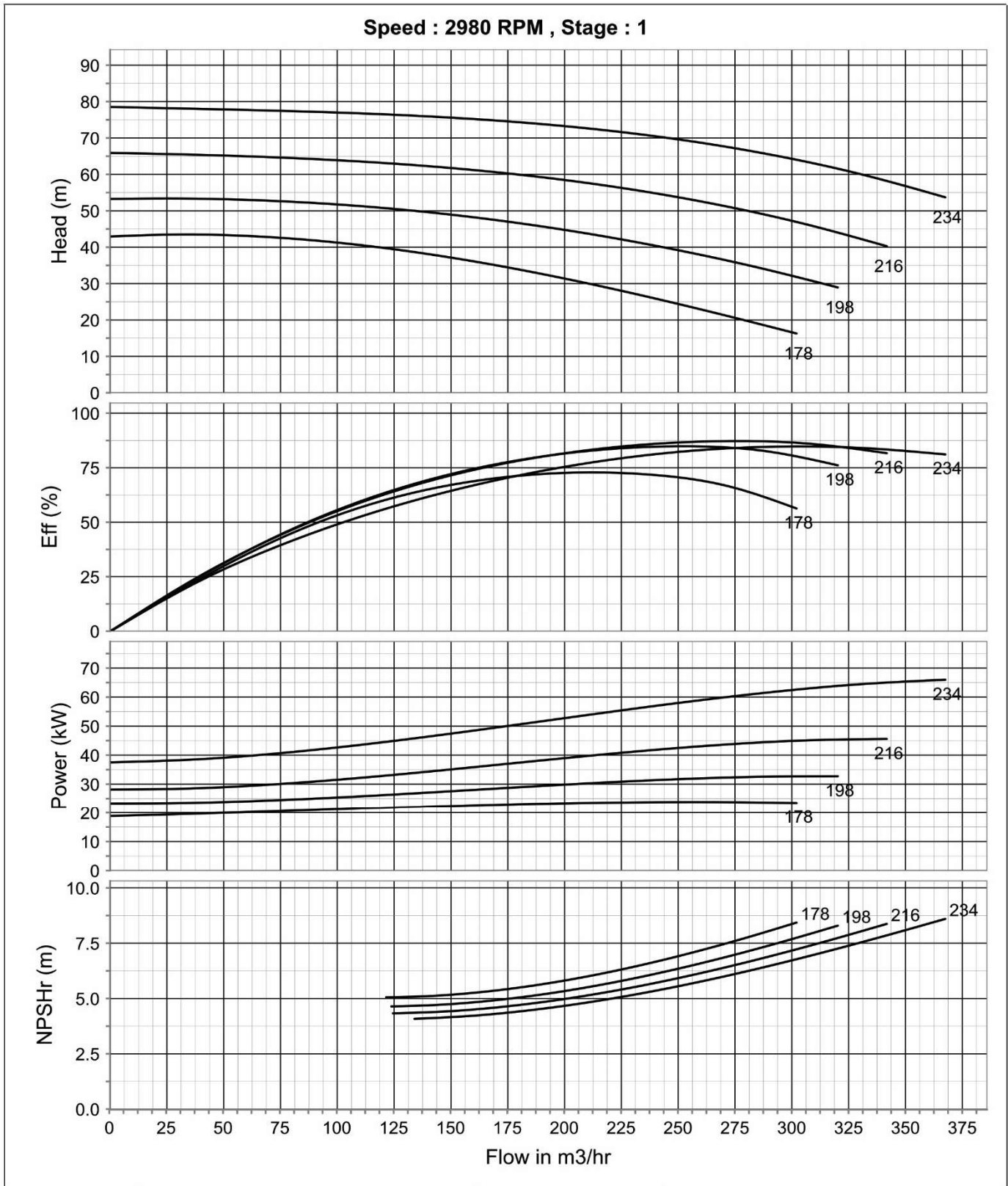

Performance Curve 2 Pole

MISO - 100 - 250 (2 - Pole)

Performance curve

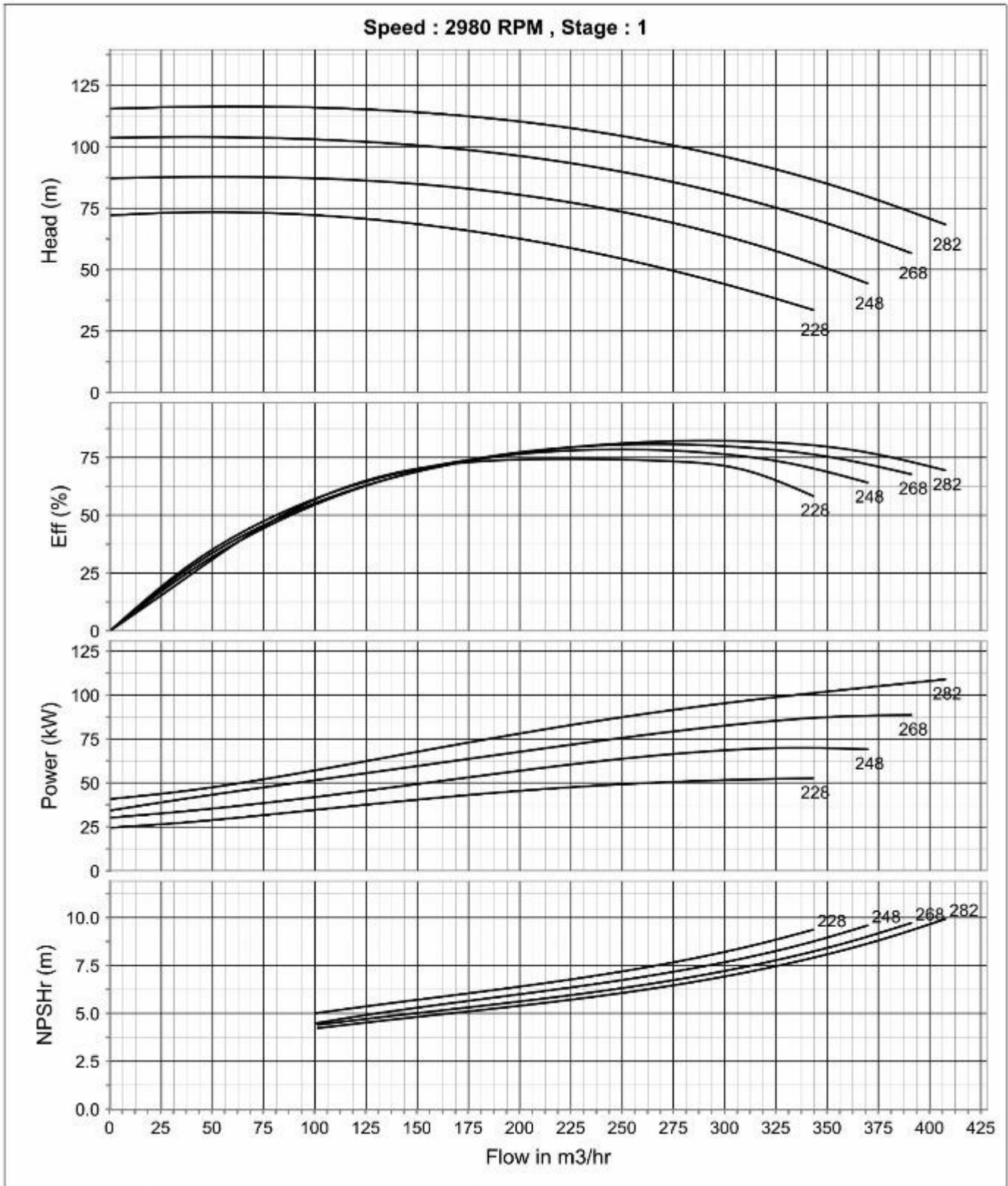

Performance Curve 2 Pole

MISO - 100 - 315H (2 - Pole)

Performance curve

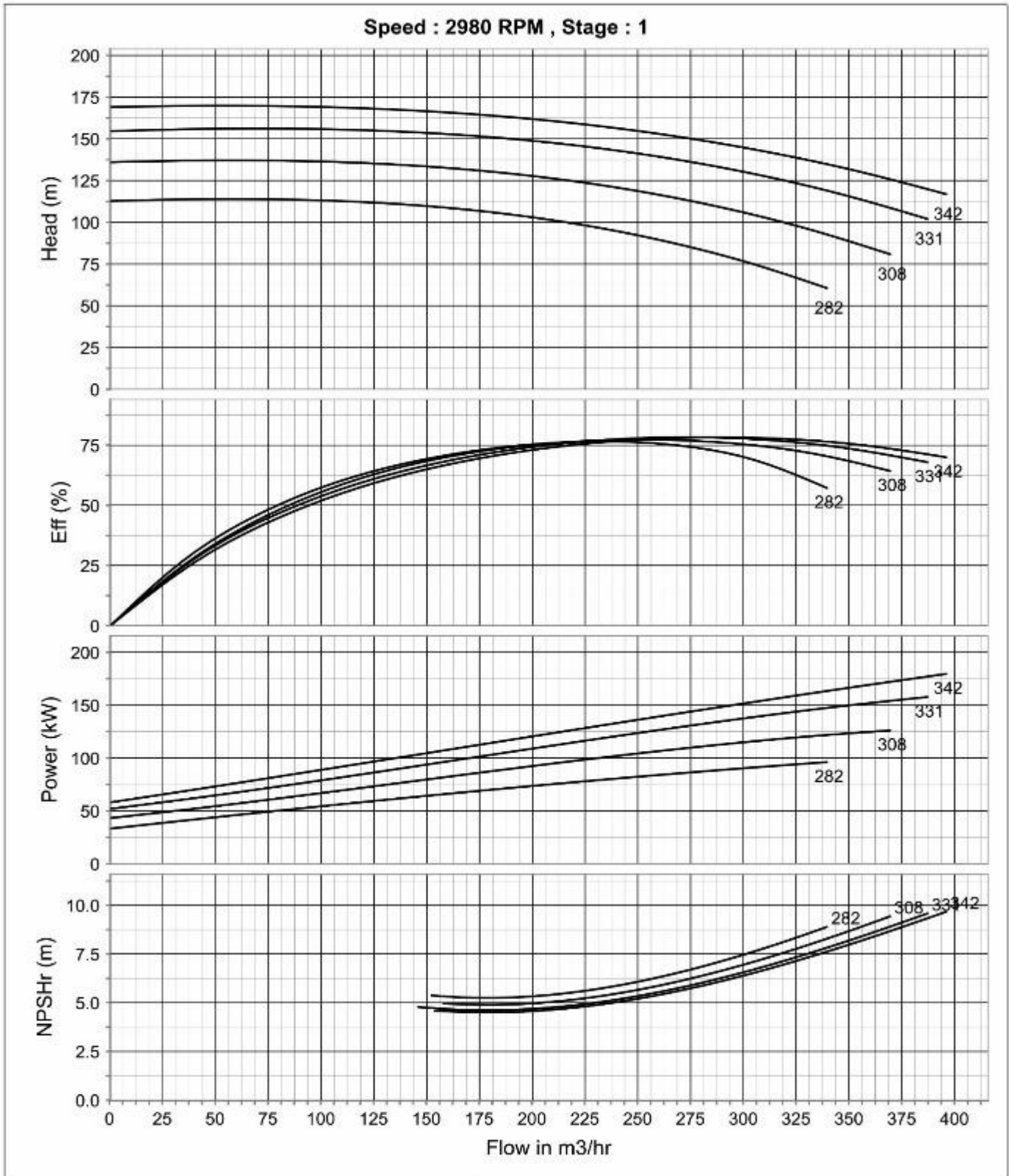

Performance Curve 2 Pole

Dimension Data - Bare Pump (2 Pole)

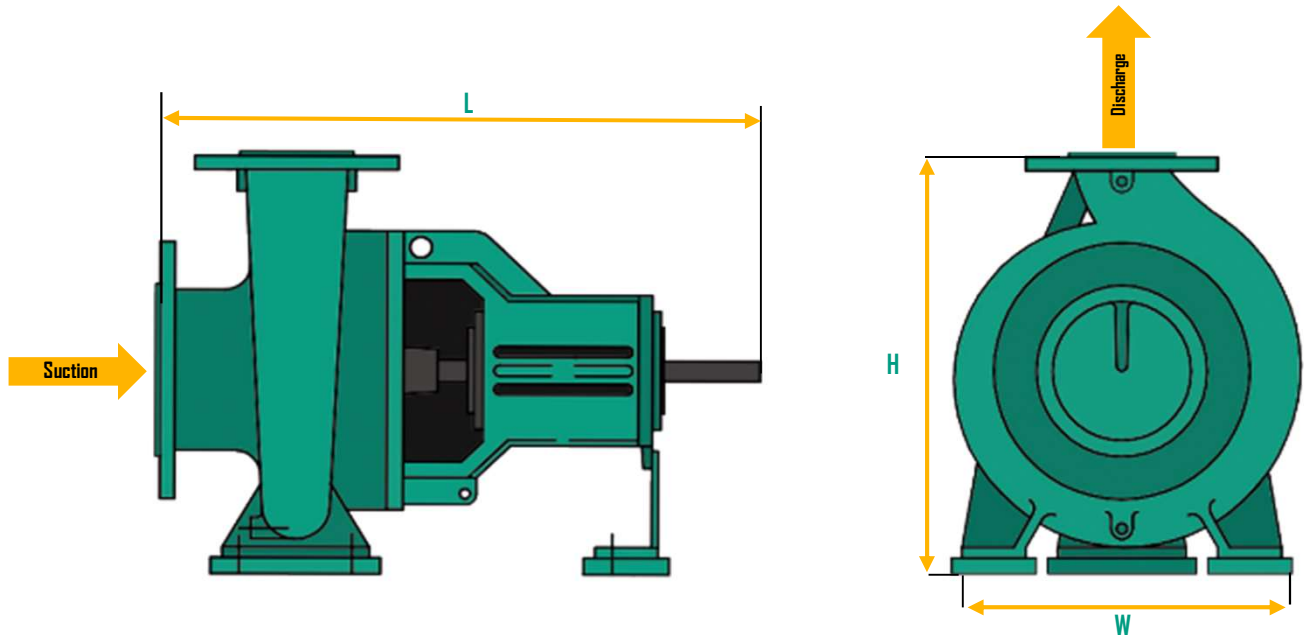

Model	Pump Size			Length (mm)	Width (mm)	Height (mm)	Mass (kg)
	Suction (mm)	Discharge (mm)	Impeller (mm)				
MISO 25-125 - 2P	40	25	125	465	180	252	32
MISO 25-160 - 2P	40	25	160	465	230	292	38
MISO 32-125 - 2P	50	32	125	465	180	252	31
MISO 32-160 - 2P	50	32	160	465	230	292	38
MISO 32-200 - 2P	50	32	200	465	230	340	45
MISO 32-250 - 2P	50	32	250	600	290	405	75
MISO 40-200 - 2P	65	40	200	485	252	340	48
MISO 40-250 - 2P	65	40	250	600	290	405	79
MISO 40-315 - 2P	65	40	315	625	332	475	95
MISO 50-125 - 2P	65	50	125	465	180	252	36
MISO 50-160 - 2P	65	50	160	465	230	292	42
MISO 50-200 - 2P	80	50	200	485	252	360	57
MISO 50-250 - 2P	80	50	250	625	290	405	84
MISO 50-315 - 2P	80	50	315	625	332	505	103
MISO 65-125 - 2P	80	65	125	485	230	292	40
MISO 65-160 - 2P	80	65	160	485	252	340	47
MISO 65-200 - 2P	100	65	200	600	290	405	79
MISO 65-250 - 2P	100	65	250	625	332	450	91
MISO 65-315H - 2P	100	65	315	655	368	505	110
MISO 80-250 - 2P	125	80	250	625	368	505	90
MISO 100-200 - 2P	125	100	200	625	332	480	90
MISO 100-250 - 2P	125	100	250	670	368	505	109
MISO 100-315H - 2P	125	100	315	670	368	565	129

MISO - 65 - 315 (4 - Pole)

Performance curve

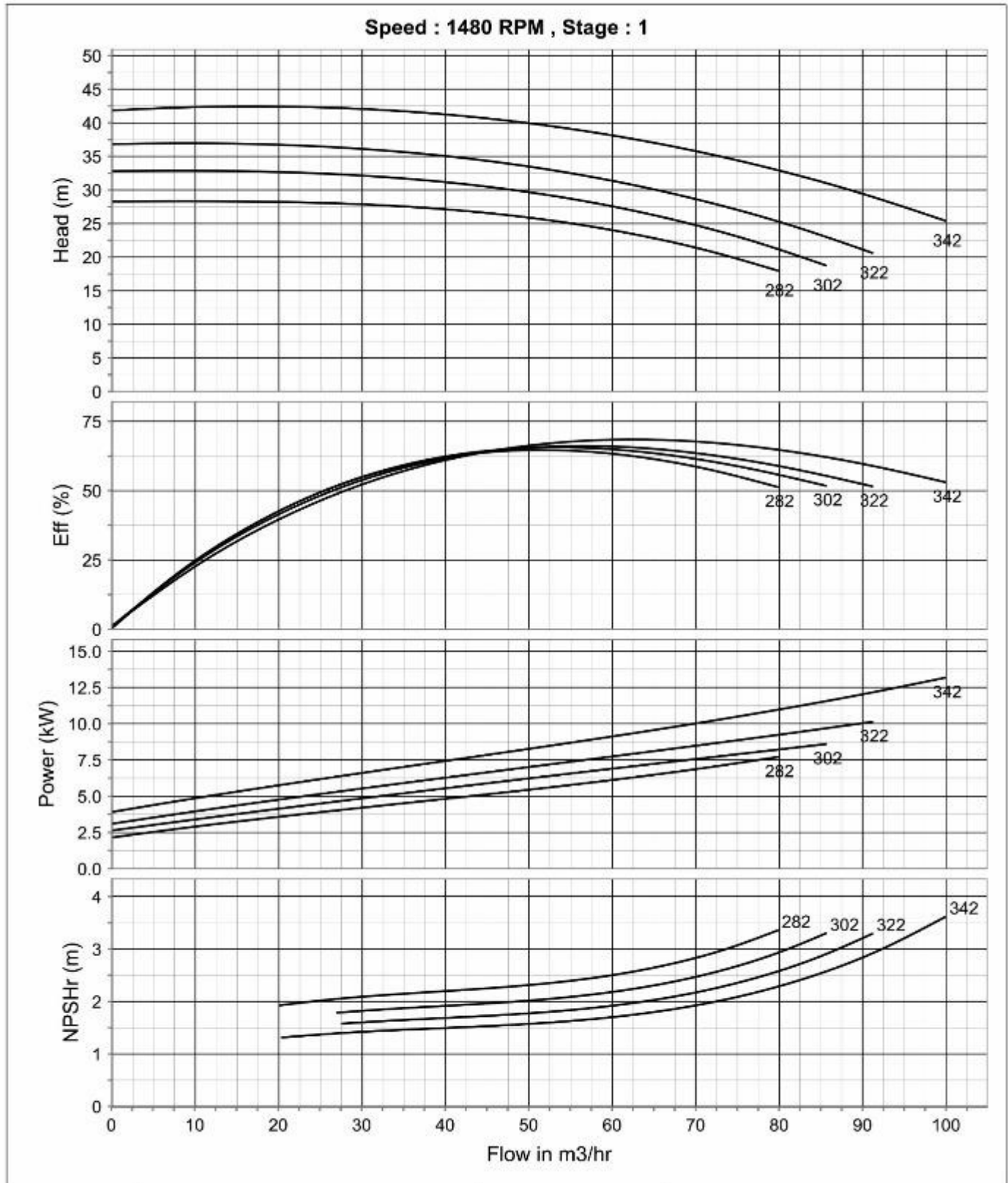

Performance Curve 4 Pole

MISO - 100 - 315 (4 - Pole)

Performance curve

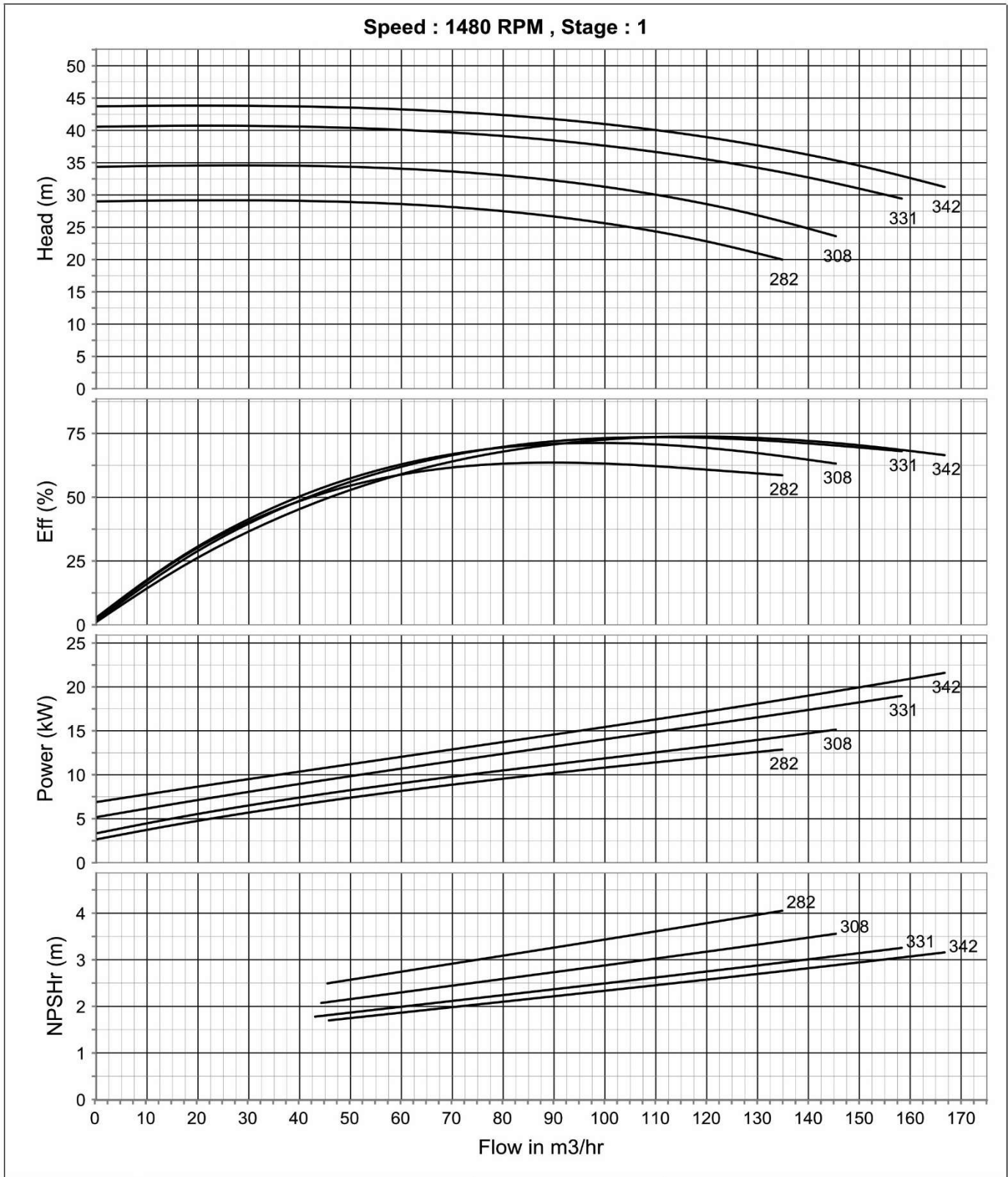

Performance Curve 4 Pole

MISO - 100 - 400 (4 - Pole)

Performance curve

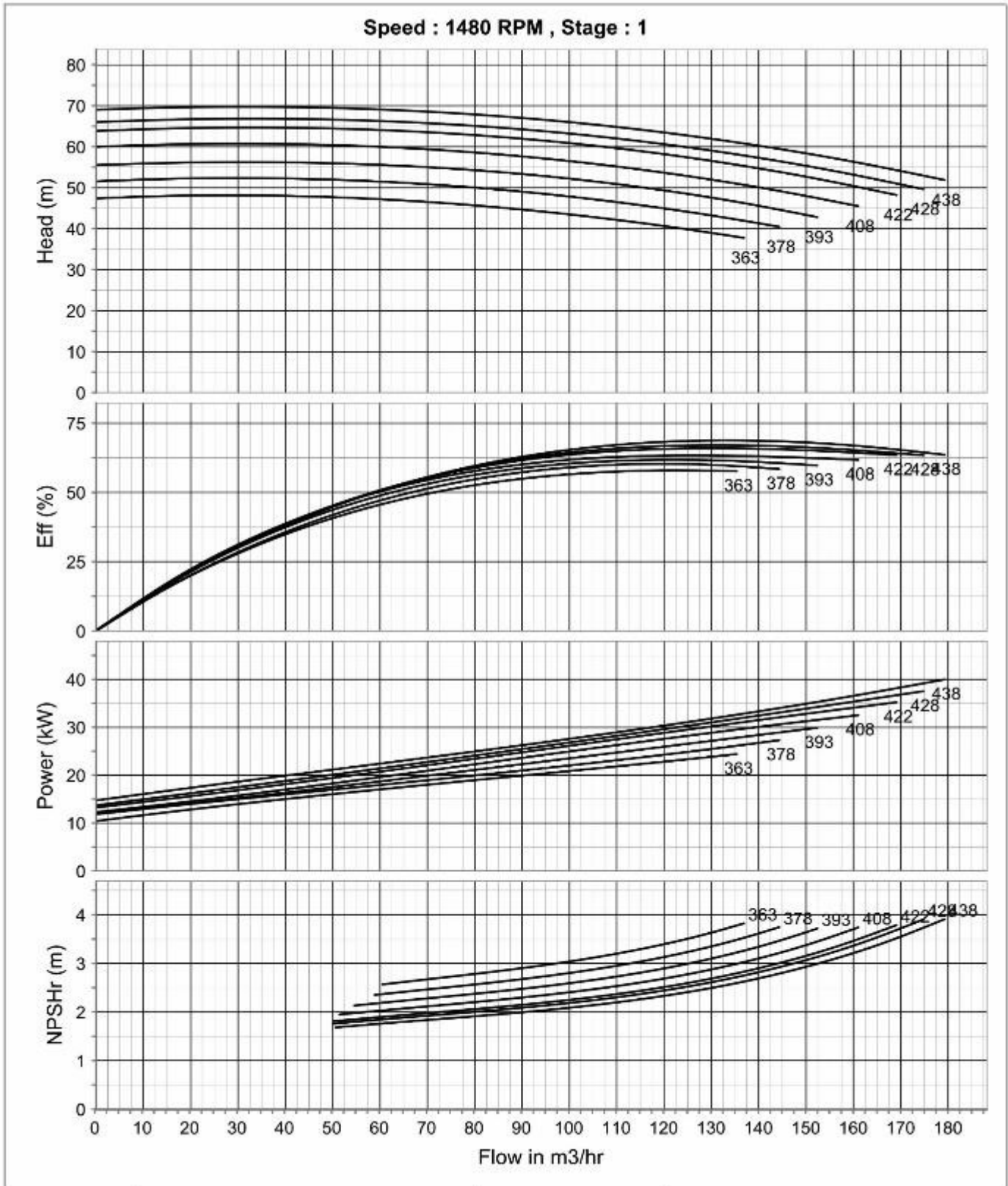

Performance Curve 4 Pole

MISO - 100 - 500 (4 - Pole)

Performance curve

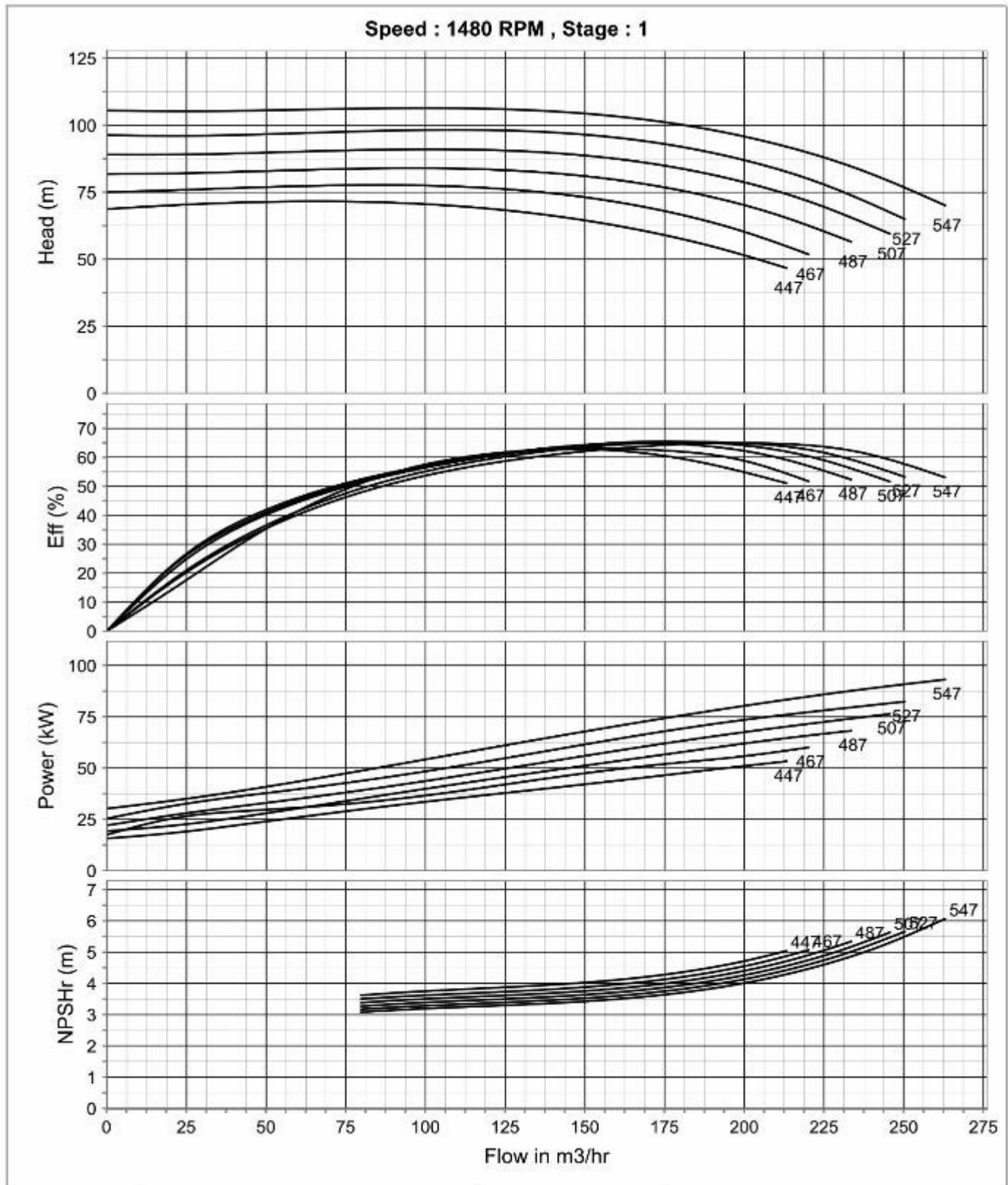

Performance Curve 4 Pole

MISO - 125 - 250 (4 - Pole)

Performance curve

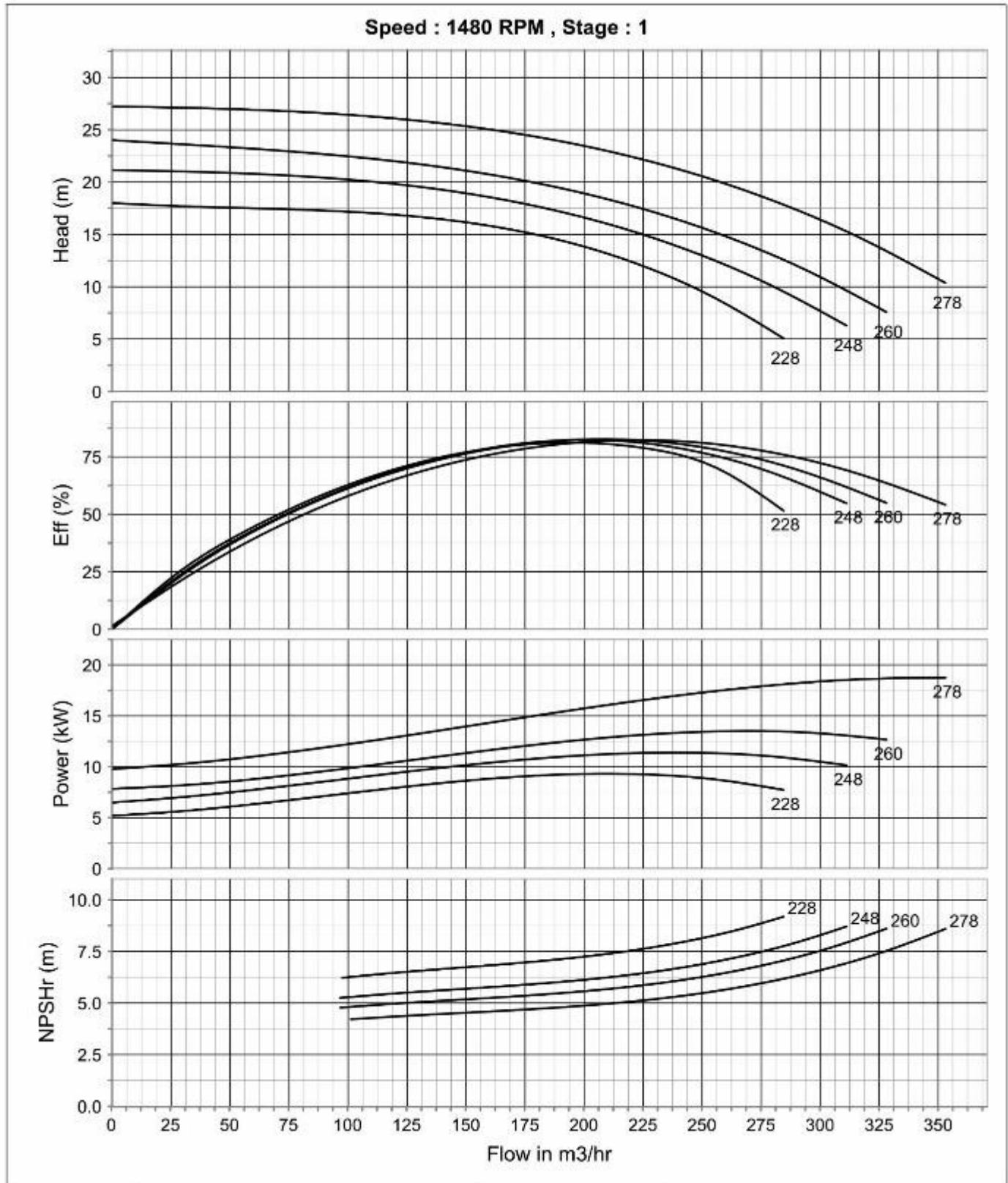

Performance Curve 4 Pole

MISO - 125 - 315 (4 - Pole)

Performance curve

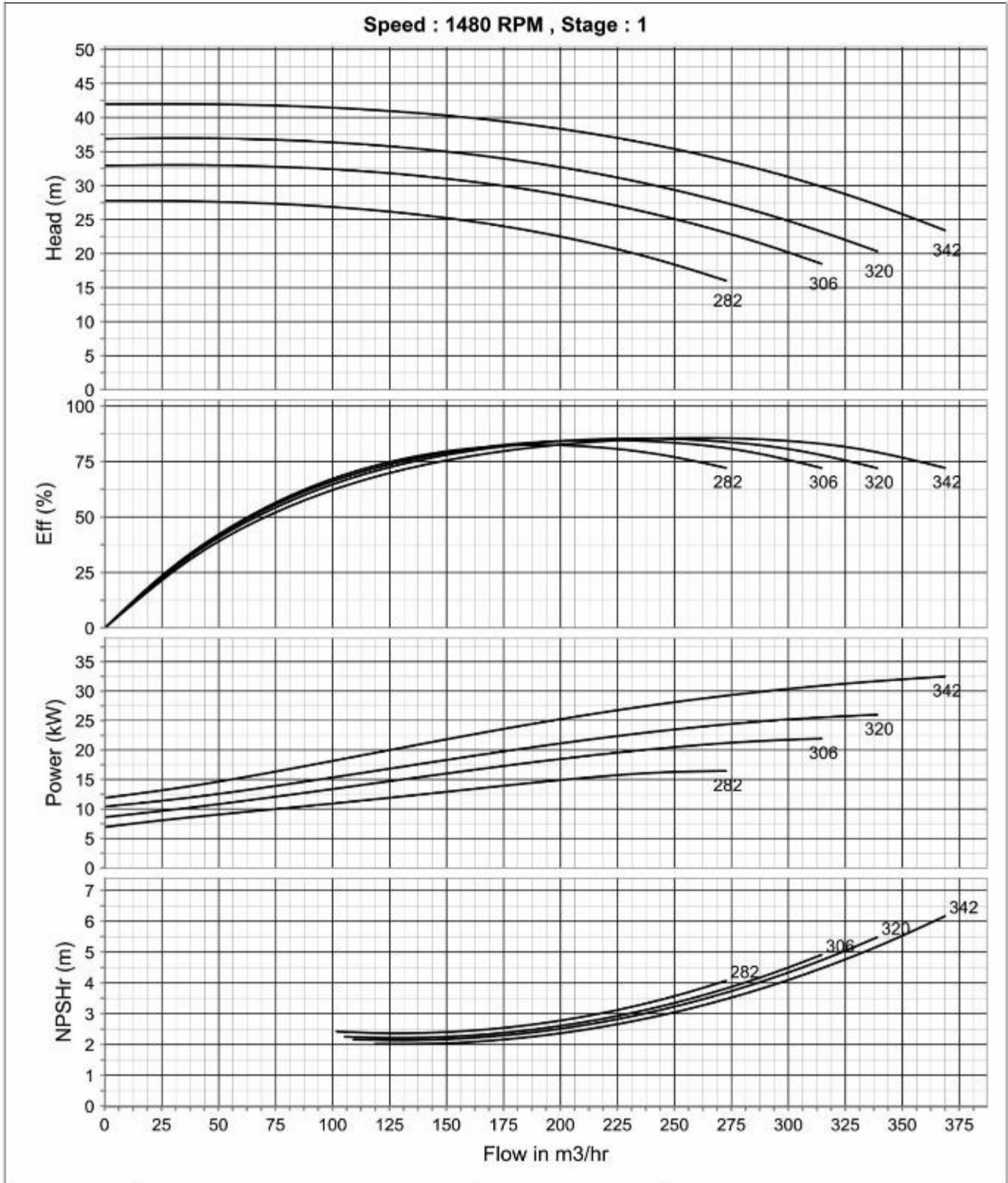

Performance Curve 4 Pole

MISO - 125 - 400 (4 - Pole)

Performance curve

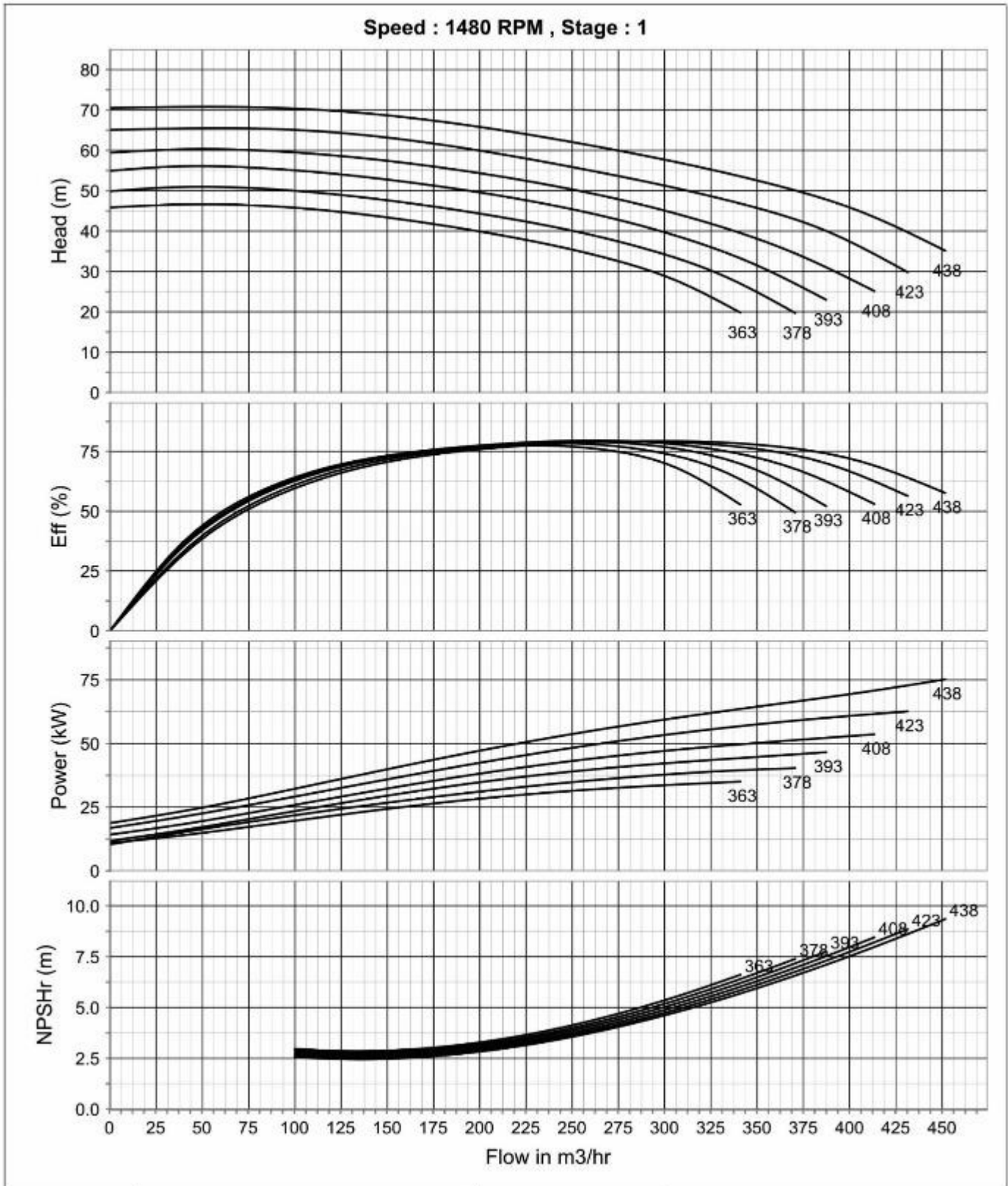

Performance Curve 4 Pole

MISO - 125 - 500 (4 - Pole)

Performance curve

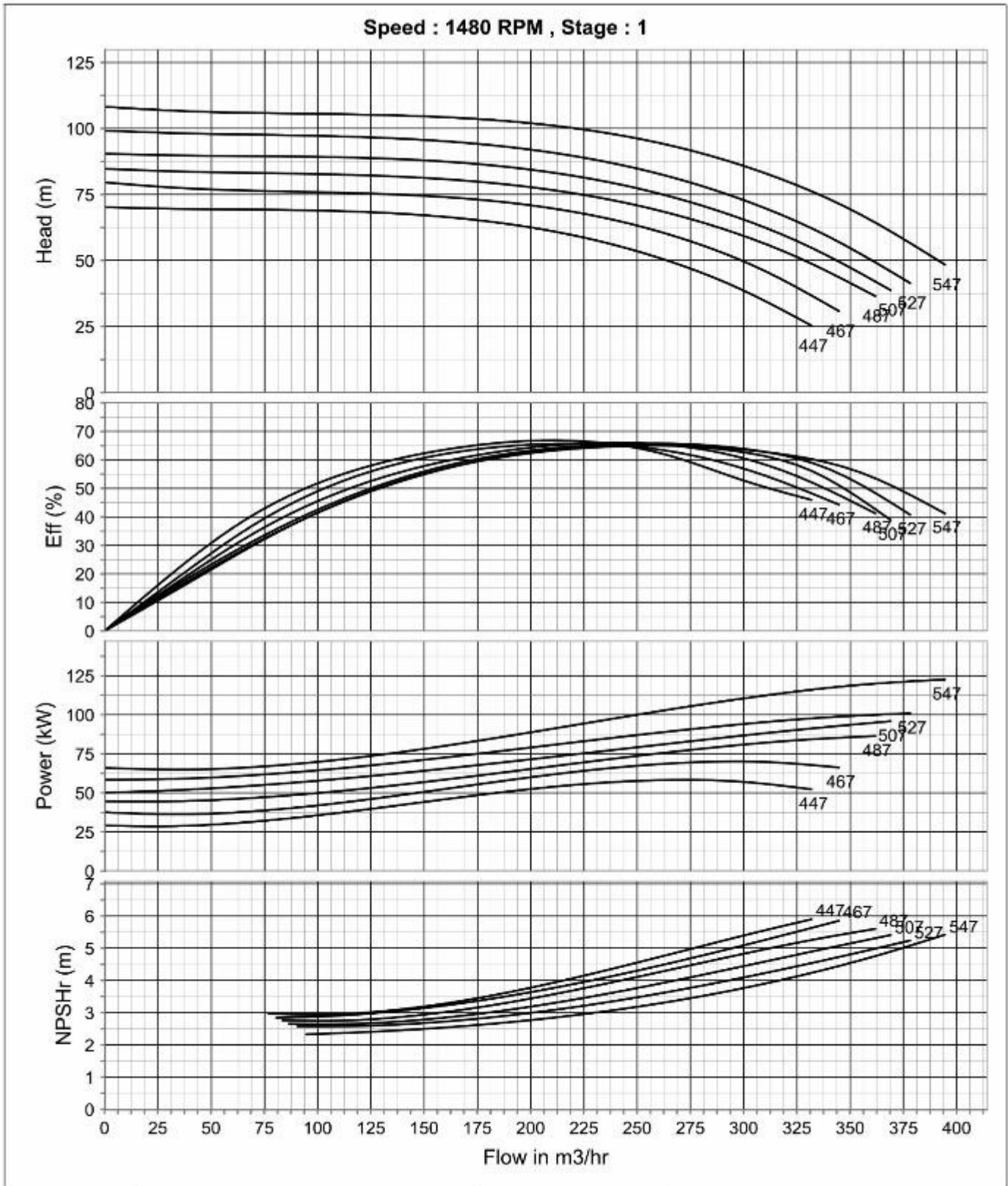

Performance Curve 4 Pole

MISO - 150 - 200 (4 - Pole)

Performance curve

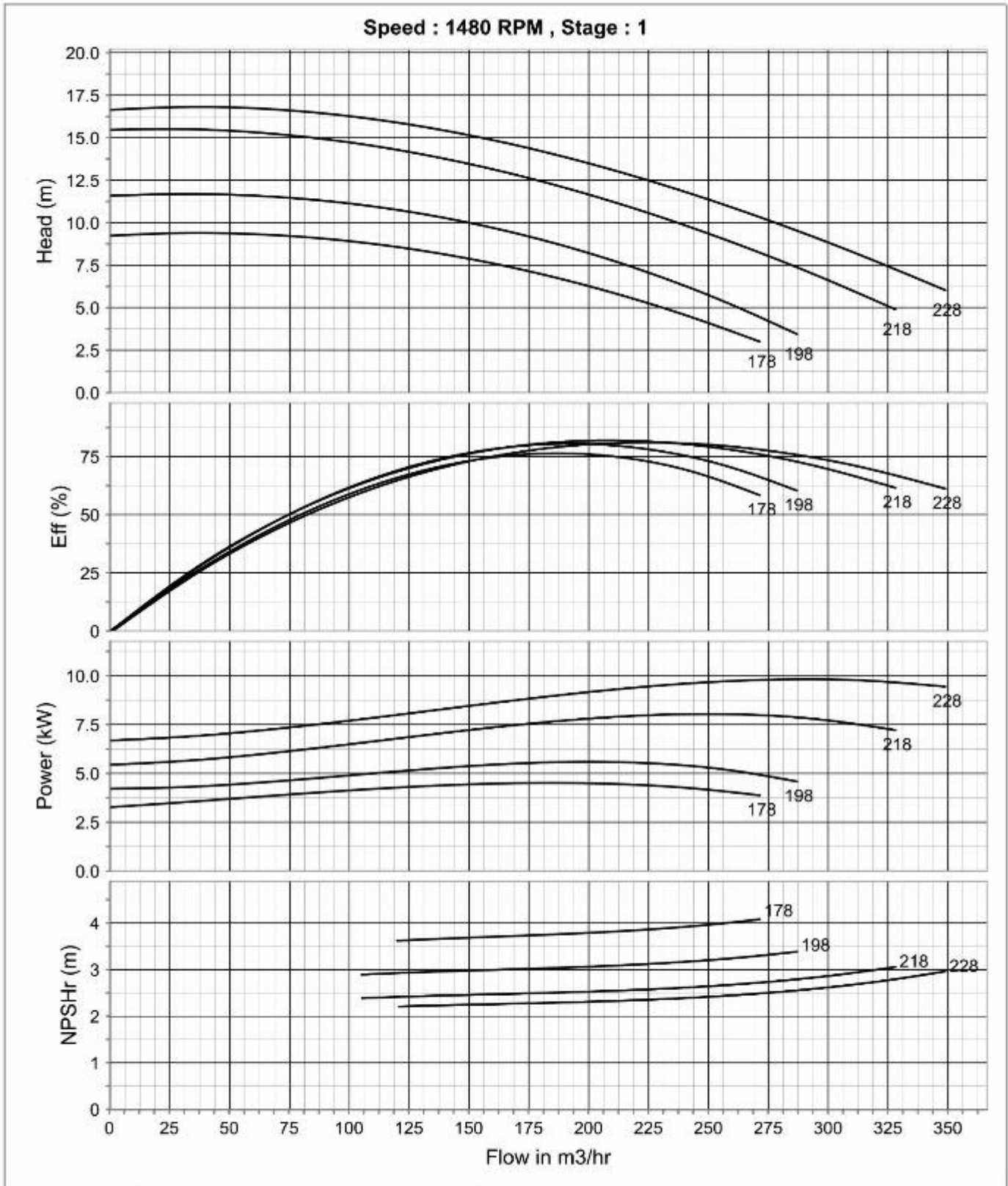

Performance Curve 4 Pole

MISO - 150 - 250 (4 - Pole)

Performance curve

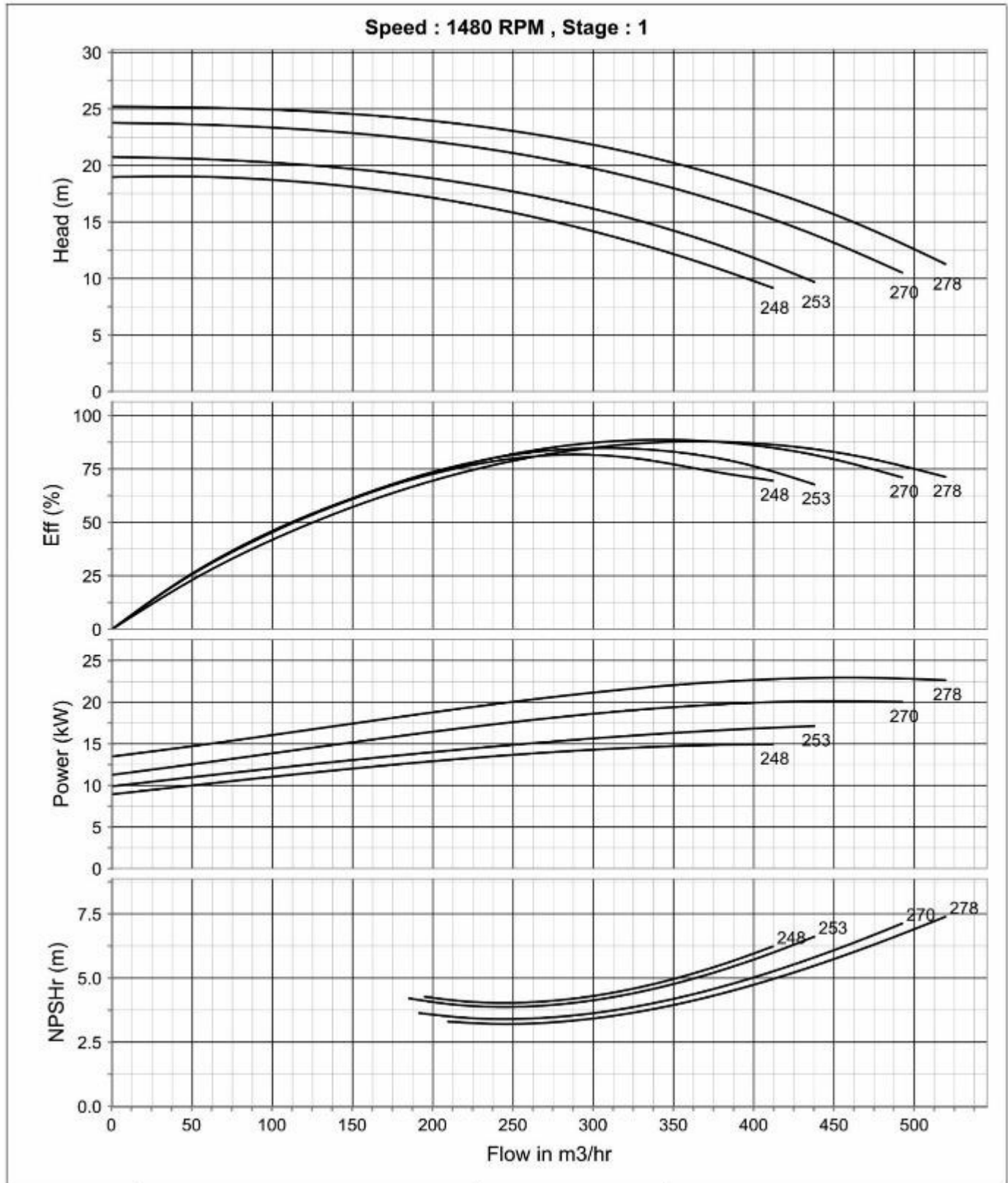

Performance Curve 4 Pole

MISO - 150 - 315 (4 - Pole)

Performance curve

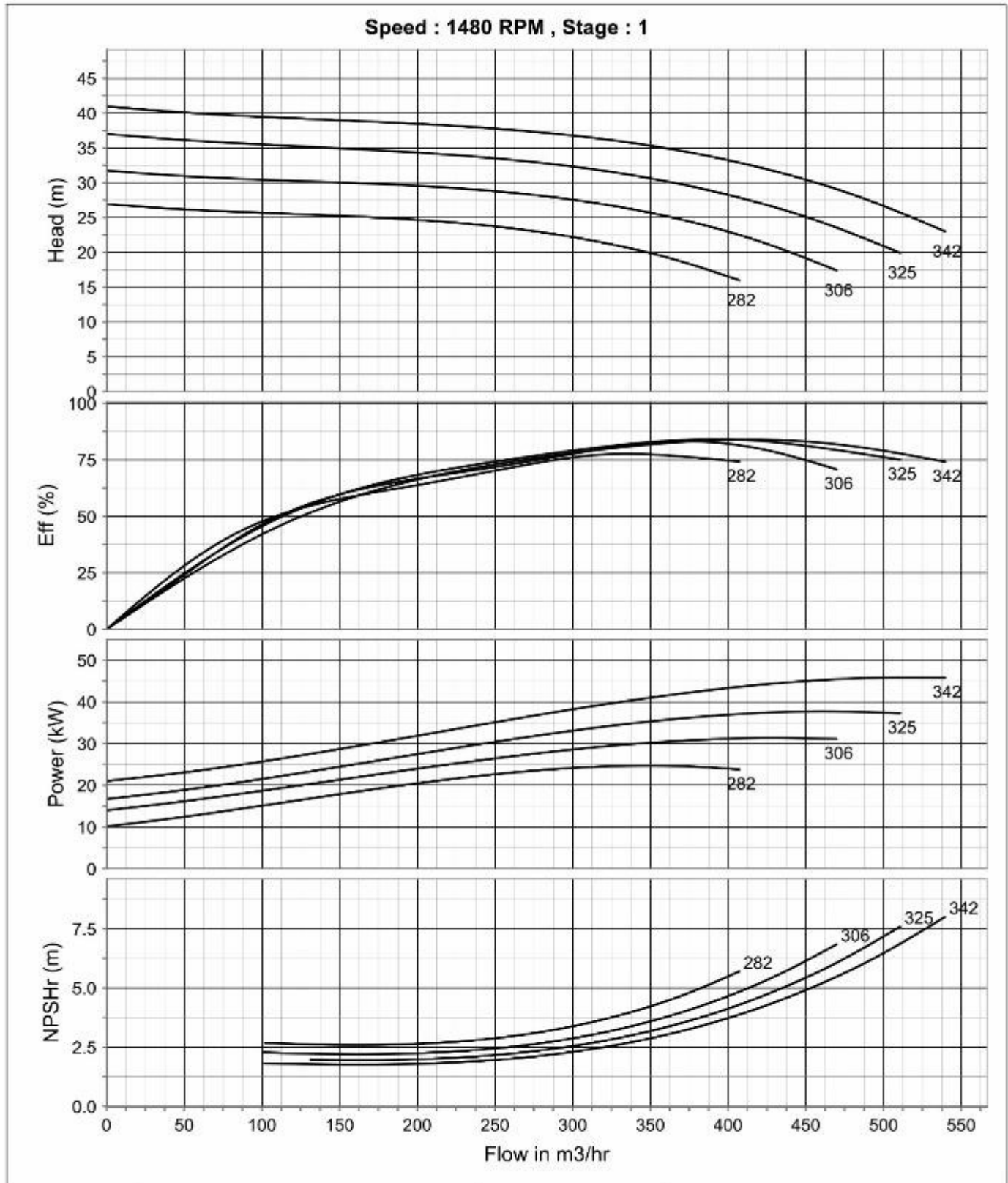

Performance Curve 4 Pole

MISO - 150 - 400 (4 - Pole)

Performance curve

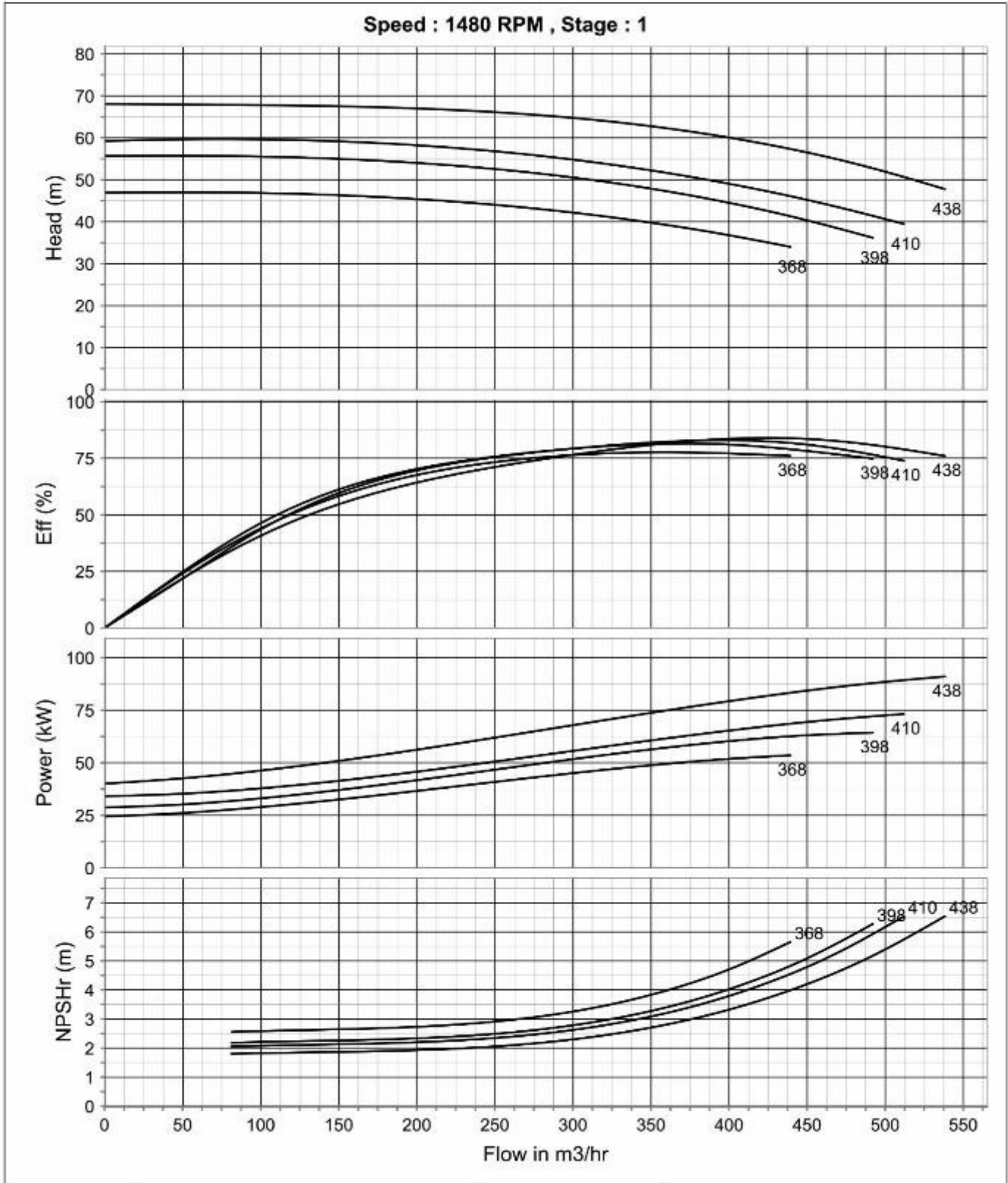

Performance Curve 4 Pole

MISO - 150 - 400 (4 - Pole)

Performance curve

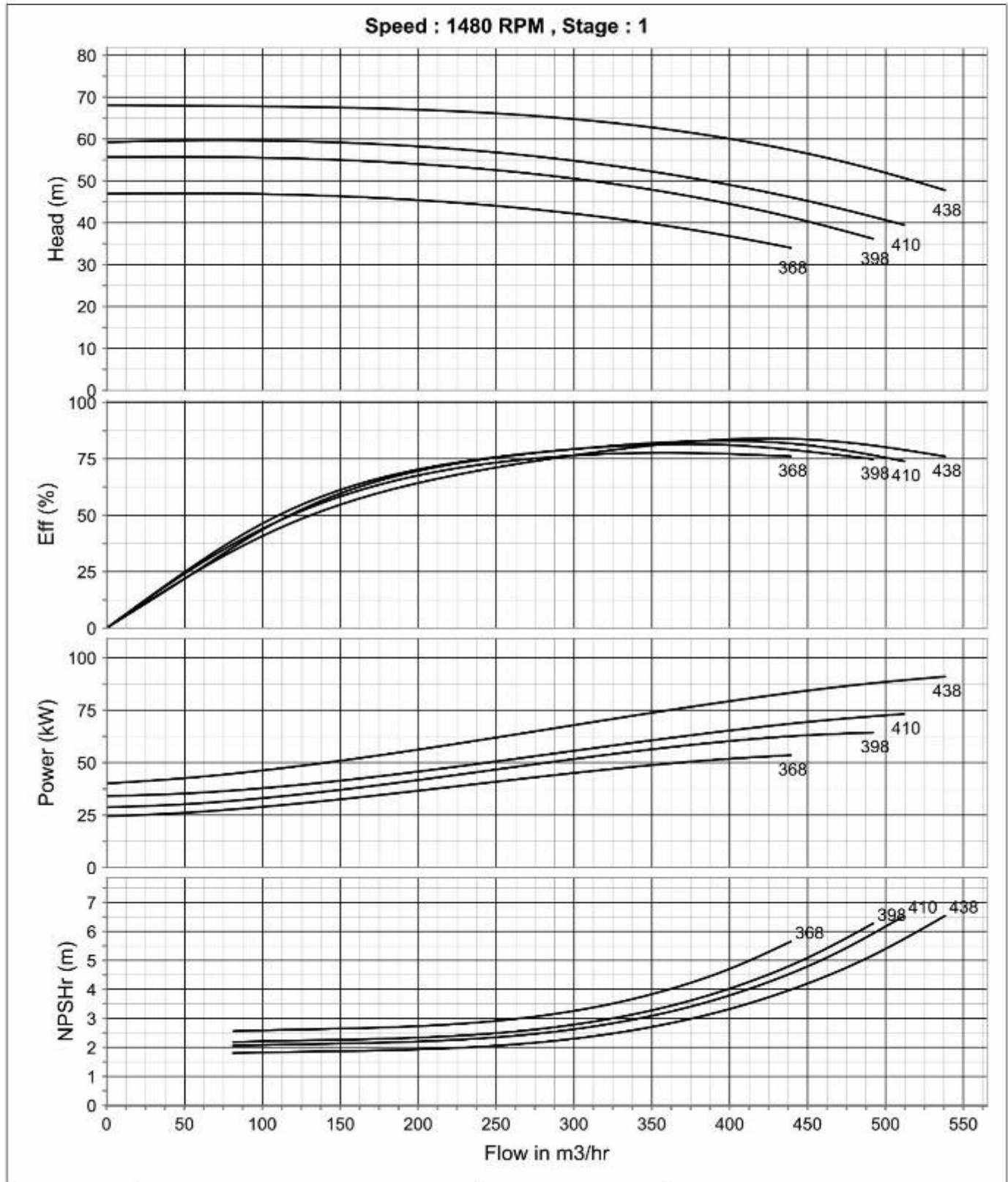

Performance Curve 4 Pole

MISO - 150 - 500 (4 - Pole)

Performance curve

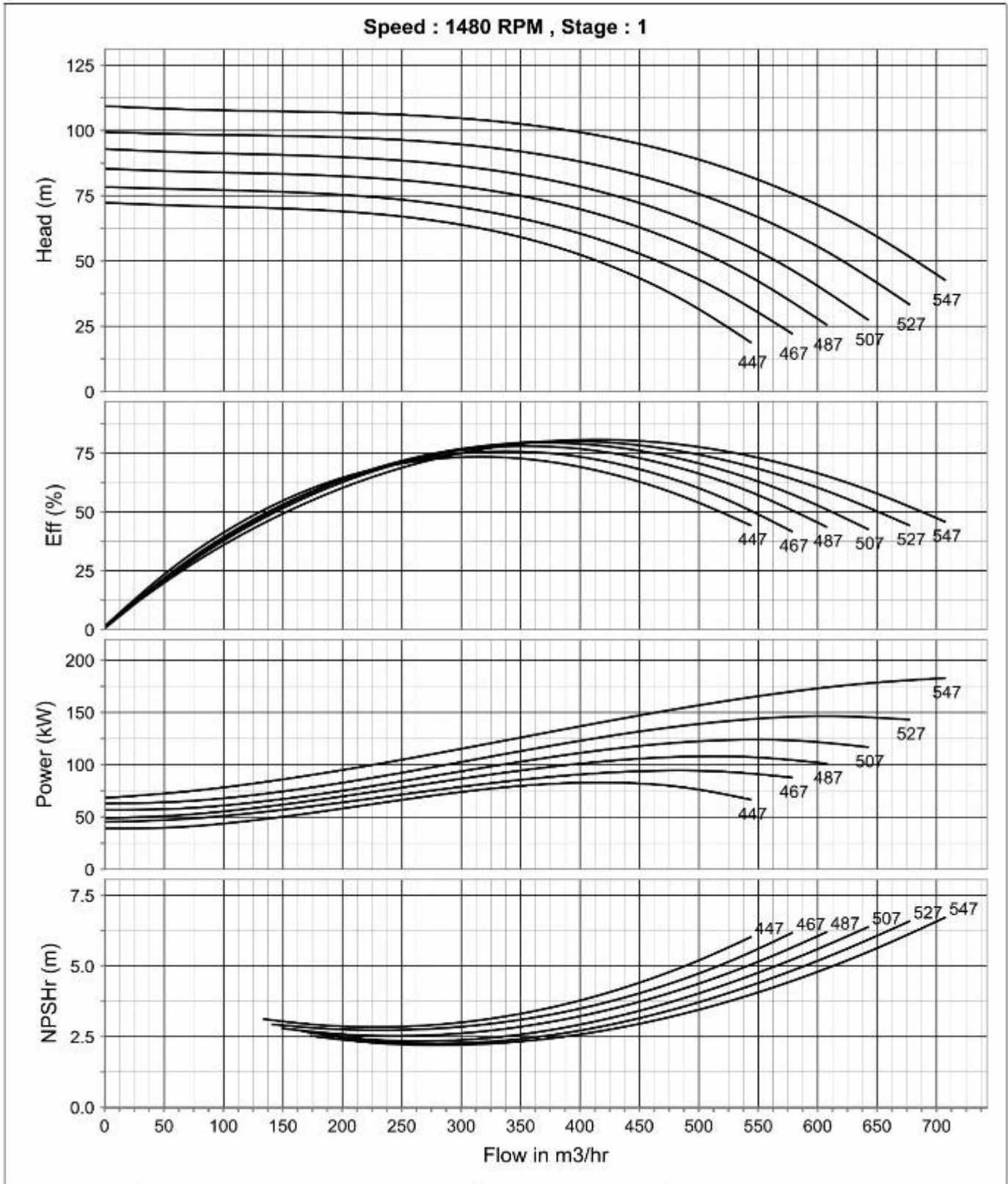

Performance Curve 4 Pole

MISO - 200 - 315 (4 - Pole)

Performance curve

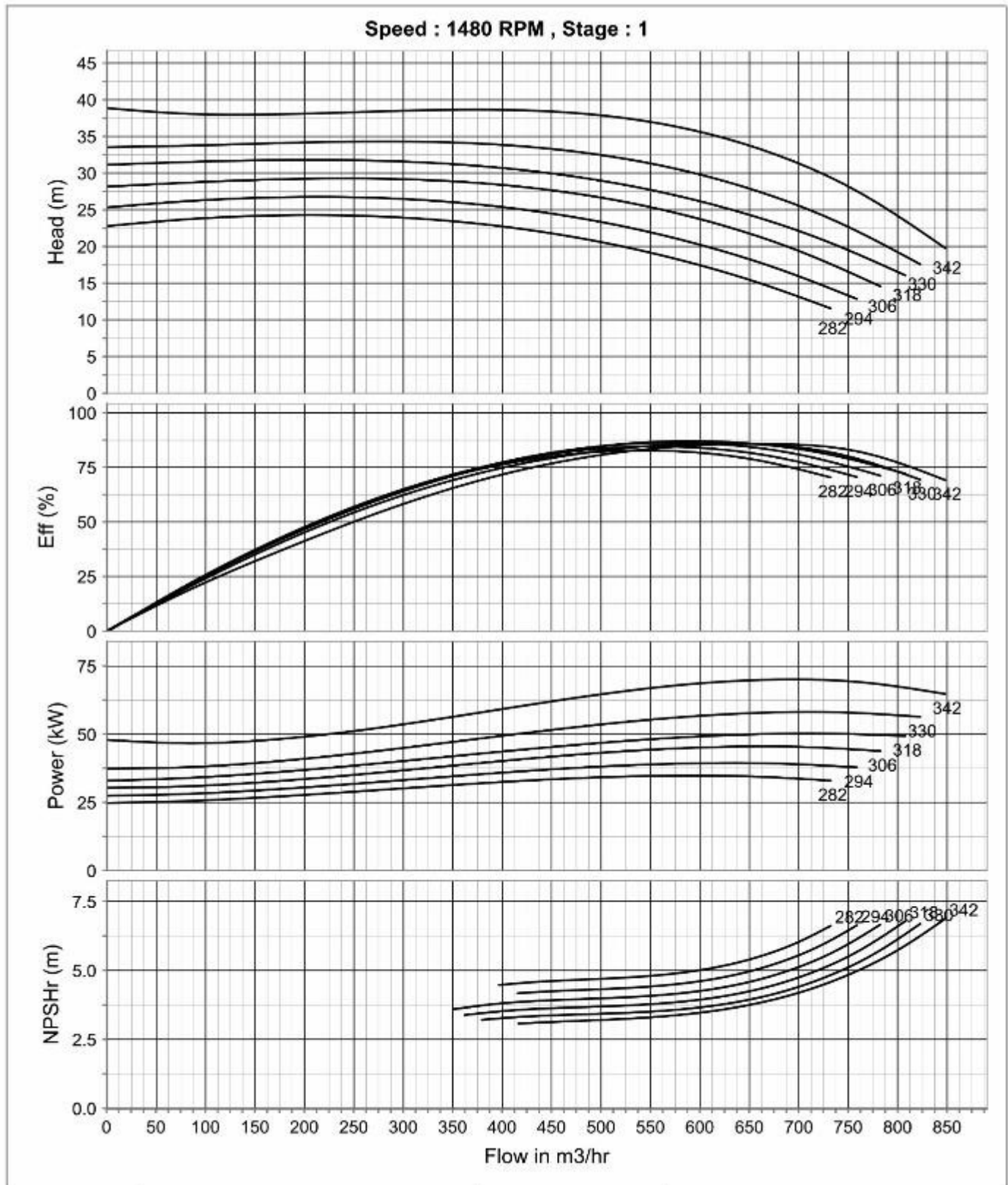

Performance Curve 4 Pole

Dimension Data - Bare Pump (4 Pole)

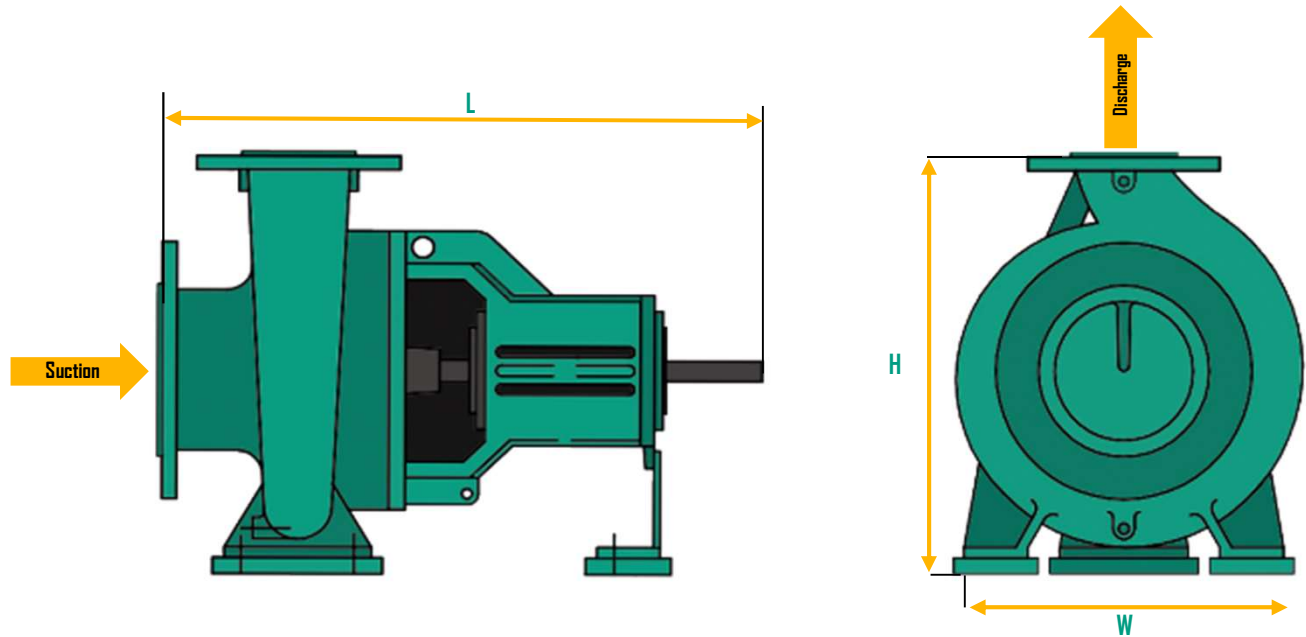

Model	Pump Size			Length (mm)	Width(mm)	Height(mm)	Mass(kg)
	Suction (mm)	Discharge (mm)	Impeller (mm)				
MISO 65-315 - 4P	100	65	315	655	368	505	110
MISO 100-315 - 4P	125	100	315	670	368	565	129
MISO 100-400 - 4P	125	100	400	670	465	635	171
MISO 100-500 - 4P	125	100	500	830	515	805	283
MISO 125-250 - 4P	150	125	250	670	368	605	125
MISO 125-315 - 4P	150	125	315	670	465	635	150
MISO 125-400 - 4P	150	125	400	670	465	715	207
MISO 125-500 - 4P	150	125	500	830	515	805	304
MISO 150-200 - 4P	150	150	200	670	368	565	122
MISO 150-250 - 4P	200	150	250	690	465	655	159
MISO 150-315 - 4P	200	150	315	830	515	715	214
MISO 150-400 - 4P	200	150	400	830	515	765	250
MISO 150-500 - 4P	200	150	500	830	515	900	344
MISO 200-315 - 4P	250	200	315	850	515	765	253

****models are not as ISO 2858 of models as follows, 25-125, 25-160,100-500,125-500,150-500**